

KODAK PROFESSIONAL HR 500 Film Scanner

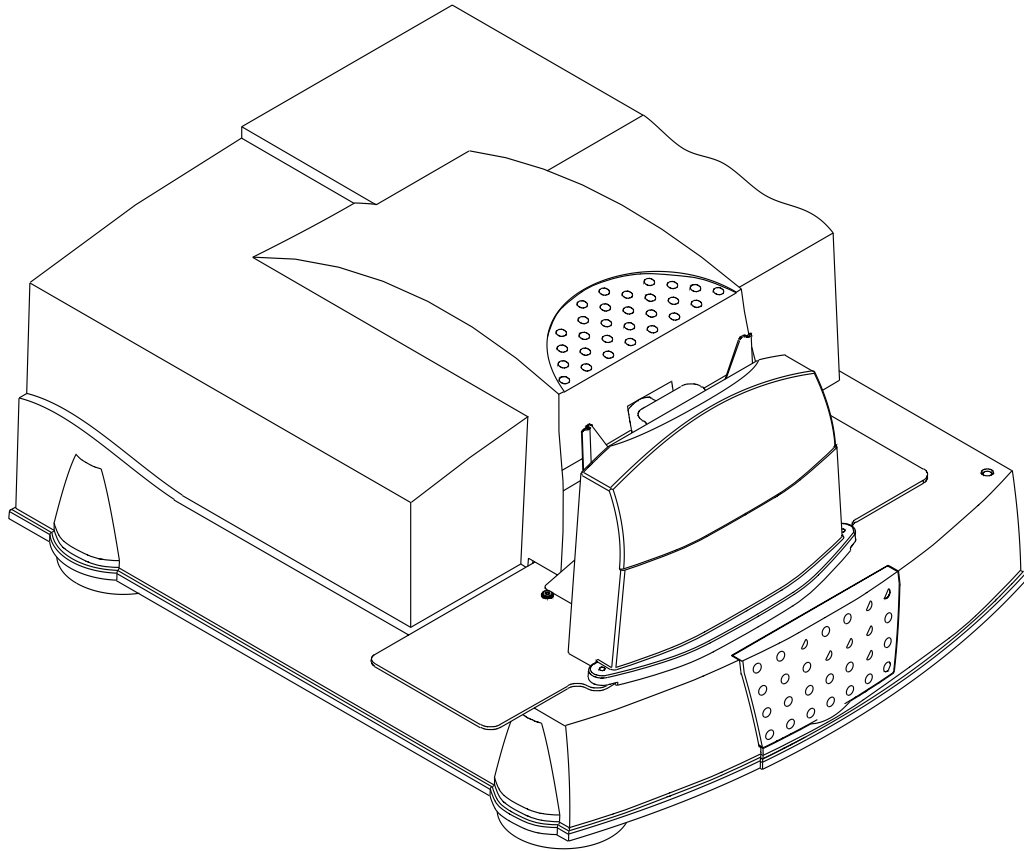

Operator's Guide

Part No. 6B6377

P015

©Eastman Kodak Company, 2000 - 2001

All rights reserved. Contents of this publication may not be reproduced in any form without permission from Eastman Kodak Company.

Unpacking Instructions for the KODAK PROFESSIONAL HR 500 Film Scanner

CAUTION: The HR 500 Film Scanner weighs almost 120 lbs (54,5 kg). Two people are needed to safely lift the scanner from the box.

Be sure the table for the scanner:

- is stable
- can support approximately 120 lbs (54,5 kg)
- is at least 30 in. (76,2 cm) long x 30 in. (76,2 cm) wide

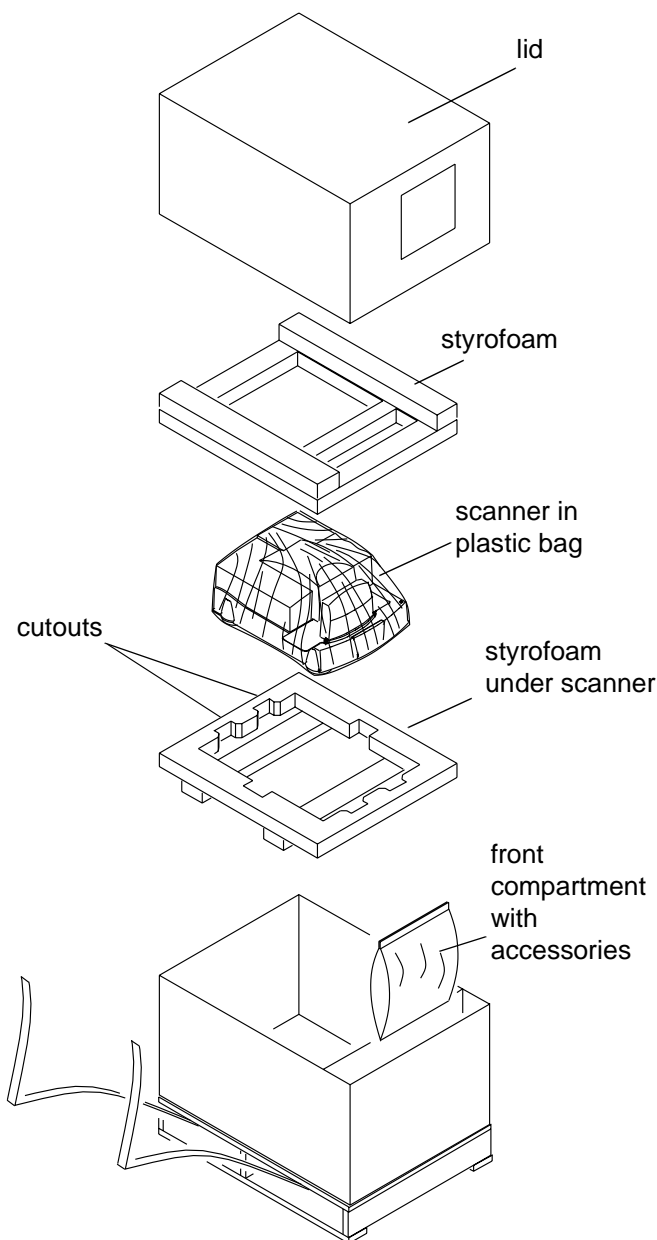

1. Inspect the box to make sure there is no damage.
If there is damage, contact the shipping company.
2. Remove the lid from the box.
3. Remove the scanner accessories (such as cables and SCSI board) from the front compartment of the box.
4. Compare the packing list to the actual contents.
If there is an item missing:
 - *In the United States:* call Eastman Kodak Company at 1-800-822-1414.
 - *Outside the United States:* contact your local Kodak representative.
5. Open the plastic bag that covers the scanner and move the bag so you can reach the cutouts in the styrofoam under the scanner.

CAUTION: Two people are needed to lift the scanner from the box.

6. Use the styrofoam cutouts to reach under the scanner (one person in front; one person in the rear) and lift the scanner out of the box onto the table.
7. Keep the scanner packing material until you are satisfied that the scanner is operating satisfactorily.

CAUTION: Make sure the setting on the AC input module on the back of the scanner is compatible with the power source.

Regulatory Information

This equipment has been tested and found to comply with the limits for a Class A device, pursuant to part 15 of the FCC rules. These limits are designed to provide reasonable protection against harmful interference when the equipment is operated in a commercial environment. This equipment generates, uses, and can radiate radio frequency energy and, if not installed and used in accordance with the instruction manual, may cause harmful interference to radio communications. Operation of this equipment in a residential area is likely to cause interference; in which case, the user would be required to incur the expense of correcting the interference.



Cautionary Symbols

Hot Surface Symbol



CAUTION: Risk of burn. Wait at least 5 minutes for surface to cool.

Fuse Label

	(2) 100-120 V 50/60 Hz 6.3 A / 250 V / F
	(2) 200-240 V 50/60 Hz 3.15 A / 250 V / T
CAUTION: Double pole / neutral fusing.	
ATTENTION: Double pôle / fusible sur le neutre.	
ACHTUNG: Zweipolige bzw. Neutraleiter - Sicherung!	

CAUTION: The *Kodak Professional* HR 500 Film Scanner uses double pole/neutral fusing.

Electrical Hazard Symbol

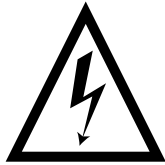

French:
Symbole de Danger Électrique

German:
Elektrisches Gefahrensymbol

CAUTION: Risk of electrical shock. Test before touching.

French:

ATTENTION: Danger D' Électrocution. Vérifier avant de toucher.

German:

VORSICHT: Gefahr von elektrischem Schlag. Vor Berührung prüfen.

Mechanical Hazard Symbol



French:
Symbole de Danger Mécanique

German:
Mechanisches Gefahrensymbol

CAUTION: Moving parts. Avoid contact.

French:

ATTENTION: Pièces en mouvement. Ne pas toucher.

German:

VORSICHT: Bewegliche Teile. Nicht berühren.

Warranty Information

The following warranty information pertains to equipment that is installed in the United States only. For equipment installed in countries other than the United States, the terms and conditions of the new equipment warranty are provided by the Kodak company in the country in which the sale is finalized, or by a Kodak-appointed distributor in those countries where Kodak does not have direct sales representation.

Warranty Period

Kodak warrants new equipment to function properly for 90 days from the date of initial installation. This warranty covers the purchaser of the equipment as well as anyone else who owns it during the warranty period.

Warranty Repair Coverage

If this equipment does not function properly during the warranty period, a Service and Support Field Engineer from Kodak will repair the equipment without charge during Kodak's normal working hours (usually 8:00 a.m. to 5:00 p.m., Monday through Friday). Such repair service will include any adjustments and/or replacement of parts required to maintain your equipment in good working order. Supply items are billed as required.

How to Obtain Service

Before you call, please know your scanner's K-Number. The K-Number label is attached to the front of the scanner chassis near the filter and lamp; lift the lamp-and-filter-access door to see the K-number (see *Front View* on page 1-4).

For service and support:

- *In the United States:* call Eastman Kodak Company at 1-800-822-1414.
- *Outside the United States:* contact your local Kodak representative.

Limitations

Warranty service is limited to areas within Kodak's established marketing centers in the contiguous United States, the island of Oahu in Hawaii, and some areas of Alaska.

This warranty does not cover circumstances beyond Kodak's control; it does not cover service or parts for any attachments, accessories, or alterations not marketed by Kodak, nor to correct problems resulting from their use.

Damage caused by failure to meet the electrical specification in this manual is not covered under the warranty to service agreement claim.

Kodak makes no other warranties, express, implied, or of merchantability, for this equipment.

Repair or replacement without charge is Kodak's only obligation under this warranty. Kodak will not be responsible for any consequential or incidental damages resulting from the sale, use, or improper functioning of this equipment, even if loss or damage is caused by the negligence or the fault of Kodak.

Such damages, for which Kodak is not responsible, include, but are not limited to, loss of revenue or profit, downtime costs, loss of use of the equipment, cost of any substitute equipment, and facilities or services of claims of your customers for such damages.

This limitation of liability does not apply to claims for injury to persons or damage to property caused by the sole negligence or fault of Kodak or by persons under its direction or control.

Kodak Service Agreements

For information on Kodak service agreements:

In the United States: call Kodak's Service Marketing Contract Administration and Billing Support at 1-800-645-6325.

Outside the United States: contact your local Kodak representative.

Contents

Regulatory Information	v
Cautionary Symbols	v
Warranty Information	vii
About This Guide	xi
Using This Guide	xi
1 Introduction and Overview	1-1
Product Description	1-1
Features and Benefits	1-2
Before You Begin	1-3
Equipment Overview	1-4
Recommended Configuration of the Host Computer	1-5
Film Sizes	1-6
2 Connecting and Operating the Scanner	2-1
Preparing the Host Computer	2-1
Connecting the Scanner	2-2
Starting Up the Scanner System	2-6
Operating the Scanner	2-8
Shutting Down the Scanner	2-13
3 Validating the Scanner	3-1
Starting the SAM Software	3-1
Setting the Magnification	3-3
Calibrating the Scanner	3-4
Making a Test Scan	3-5
Autofocusing	3-7
Scanning the Image	3-8
Checking the Scan	3-8
4 Maintaining the Equipment	4-1
Cleaning Procedures	4-1
Replacement Procedures	4-4
Appendix A: Using the Service and Assembly Module (SAM)	A-1
Installing the Service and Assembly Module (SAM) Software	A-2
Using the Operations Controls	A-3
Appendix B: Ordering Accessories and Supplies	B-1
Accessories	B-1
Supplies	B-2
Appendix C: Scanner Specifications	C-1

Appendix D: Using the Long Roll Accessory	D-1
Installing the Software for the Long Roll Accessory	D-2
Installing or Removing the Long Roll Accessory	D-5
Punch Sensors	D-14
Setting the Punch Reader Height for the Current Film Size	D-14
Appendix D-1: Calibrating the Sensor Offsets	D-24
Appendix D-2: Determining and Setting the Trigger Points	D-34
Appendix D-3: Maintenance	D-38
Appendix D-4: Initial Setup of Sensors	D-42
Appendix D-5: Table of Scan Area Values	D-45
Appendix D-6: Film Splicing and Editing Guidelines	D-46

About This Guide

This *Operator's Guide for the KODAK PROFESSIONAL HR 500 Film Scanner* includes procedures for operating, maintaining, and troubleshooting the scanner. It also includes an appendix for the optional Long Roll Accessory.

This guide is intended for personnel who operate the scanner. It assumes you have a basic knowledge of computer operations and film scanners.

Using This Guide

The guide is organized as follows:

- Chapter 1* **Introduction**—product description, features and benefits, equipment overview, and recommended configuration
- Chapter 2* **Connecting and Operating the Scanner**—connecting the *Kodak Professional HR 500 Film Scanner* to the host computer, starting up the scanner, preparing to scan an image, performing a scan and shutting down the scanner
- Chapter 3* **Validating the Scanner**—instructions for using the Service and Assembly Module (SAM) and *Adobe PhotoShop* software to validate that the scanner functions properly
- Chapter 4* **Maintaining the Equipment**—procedures to be done by the person in your lab who is responsible for maintenance of the scanner
- Appendix A* **Using the Service and Assembly Module (SAM)**—an overview of using SAM for validating the scanner and for other user functions
- Appendix B* **Ordering Accessories and Supplies**—includes descriptions and order numbers for scanner accessories and supplies
- Appendix C* **Scanner Specifications**—includes space, electrical, and environmental requirements for the scanner
- Appendix D* **Using the Long Roll Accessory**—instructions for installing and using the (optional) Long Roll Accessory with the scanner

1 Introduction and Overview

This chapter includes:

- product description
- features and benefits
- equipment overview
- recommended configuration for host computer
- film sizes

Product Description

The *Kodak Professional HR 500* Film Scanner is designed to quickly generate high-resolution digital images from photographic negatives and positives.

The scanner accepts films ranging from 35 mm to 70 mm widths, including 46 mm width film and the 120 series formats, with up to 90 mm frame lengths.

The scanner digitally captures images and stores them in files up to 128 MB (format dependent) in size. The scanner is capable of variable magnifications from 0.5 to 2.0.

How the Scanner Works

The image on the film is focused onto a Charged Coupled Device (CCD) that has three parallel linear rows of light-sensitive elements, one row for each color. Each of these lines is exposed to a corresponding line of image on the film. The time to expose each line properly is controlled electronically and is a function of the:

- sensitivity of the CCD
- amount and spectral distribution of light from the light source
- lens aperture
- magnification factor

After the exposure, the data from the photosensitive sites on the CCD is transferred to readout registers for each line, where it is then shifted out and digitized one pixel at a time. While the data is shifted out, the next set of lines is exposed.

The film is moved to expose a new line of the image for each set of lines read from the CCD. This motion is precisely controlled to ensure that the aspect ratio of the image is not changed and that the colors align correctly when the data is recombined to correct for the distance between the sensor rows.

Features and Benefits

Features and benefits of the HR 500 Film Scanner include:

- high speed and high image quality digital capture
- handling of cut negatives, mounted slides, strips, short rolls, and long roll lengths up to 200 feet (61 meters)
- compatibility with familiar software, such as
 - *Kodak Professional* Digital Print Production Software (DP2)
 - *Kodak Professional* HR 500 TWAIN Data Source, which can be used with any TWAIN-compliant program
- compatibility with familiar hardware, such as *Kodak Professional* Digital Multiprinters and *Kodak Professional* LED Printers

Before You Begin

It is important that you know when to calibrate and when to focus the scanner. The table below is a guideline for calibrating and focusing. Focusing can occur as infrequently as when a different film format is scanned or as frequently as every scan.

Action or Condition	Need to Calibrate?	Need to Focus?
Changing the magnification	Yes	Yes
Replacing the lamp	Yes	No
Changing the balance filter position from negative to positive or from positive to negative	Yes	Yes
The scanner has not been calibrated at least twice during the first half of a production shift	Yes	No
Cleaning the light bar	Yes	No
Replacing the balance filters or the IR filter	Yes	No
Changing the film holder without changing the magnification	Yes	Operator Preference
Scanning slides	No	Operator Preference
Changing from scanning a long roll to scanning a cut negative	Yes	Yes

You can manipulate scanned images using a program such as the *Kodak Professional Digital Print Production Software (DP2)* or the *Kodak Professional HR 500 TWAIN Data Source* before sending the images to your digital printer.

Equipment Overview

Front View

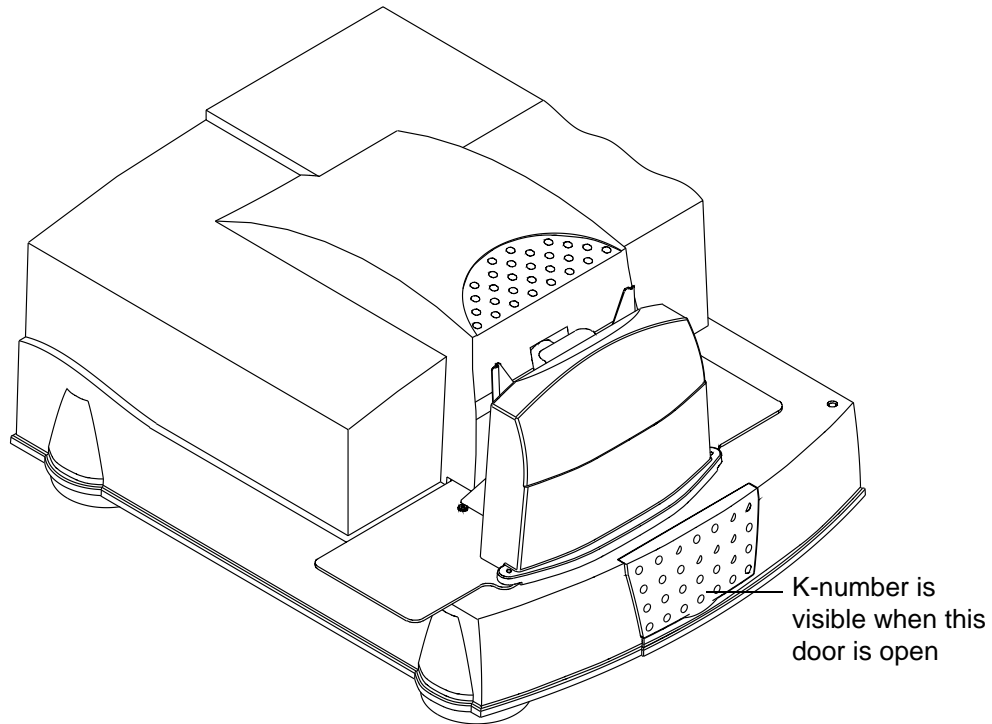

Rear View

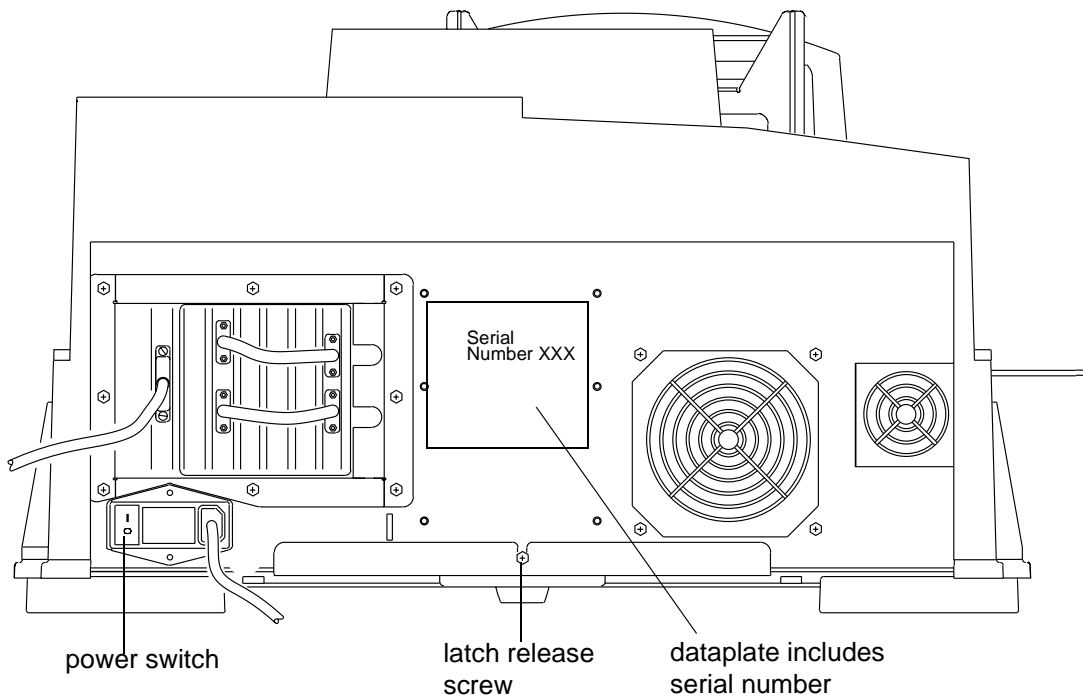

Recommended Configuration of the Host Computer

The scanner is designed to communicate with *Windows* NT and *Windows* 2000 platforms with the following configuration.

IMPORTANT: *To ensure proper operation of the scanner, use the Ultra-Wide SCSI board provided with the scanner.*

Built-in SCSI interfaces in some computers may interfere with the provided Ultra-Wide SCSI board.

Minimum Host Computer Hardware Requirements

- Dual Pentium III/600 MHz
- 512 MB memory
- 10 GB available disk space
- Dedicated SCSI host adapter (provided with scanner)

NOTES: The hardware configuration is a minimum; for higher performance, a high speed and larger memory capacity machine is required.

The SCSI board must be dedicated to running only the HR 500 Film Scanner.

A SCSI cable connects the host computer to the scanner. This interface enables the transfer of digital image data from the scanner to the host computer.

Minimum Software Requirements

- *Windows* NT 4.0, Service Pack 6 for using the scanner and software
- *Adobe Photoshop* 5.5 or higher for validating operation of the scanner

Film Sizes

Commonly available color negative, color reversal (positive), and black-and-white films are supported by the scanner.

The scanner accepts these film sizes:

- 35 mm
 - standard perforated format
 - un-perforated, up to 60 mm frame length
- 46 mm, up to 90 mm frame length
- 120/220 (62 mm)
 - 6 x 4.5 cm
 - 6 x 6 cm
 - 6 x 7 cm
 - 6 x 8 cm
 - 6 x 9 cm
- 70 mm
 - split 70 mm
 - full 70 mm

Film Holders Provided with the Scanner

Cut-gate film holders for these film sizes are provided with the scanner:

- 35 mm double-perforated
- 35 mm mounted slides
- 70 mm-CAL
- 6 x 4.5 cm vertical
- 6 x 4.5 cm horizontal
- 6 x 6 cm
- 6 x 7 cm
- 6 x 9 cm

2 Connecting and Operating the Scanner

This chapter gives instructions for:

- preparing the host computer
- connecting the *Kodak Professional* HR 500 Film Scanner to the host computer
- starting up the scanner system
- preparing to scan an image
- performing a scan
- shutting down the scanner

Preparing the Host Computer

CAUTION: Do not connect power to the scanner.

1. Install the Ultra-Wide SCSI board into the host computer.

IMPORTANT: Check the *README* file for your operating system before you install the software.

2. Install the SAM software. See *Installing the Service and Assembly Module (SAM) Software* on page A-2.

Connecting the Scanner

CAUTION: Make sure the setting on the AC input module on the back of the scanner agrees with the power source.

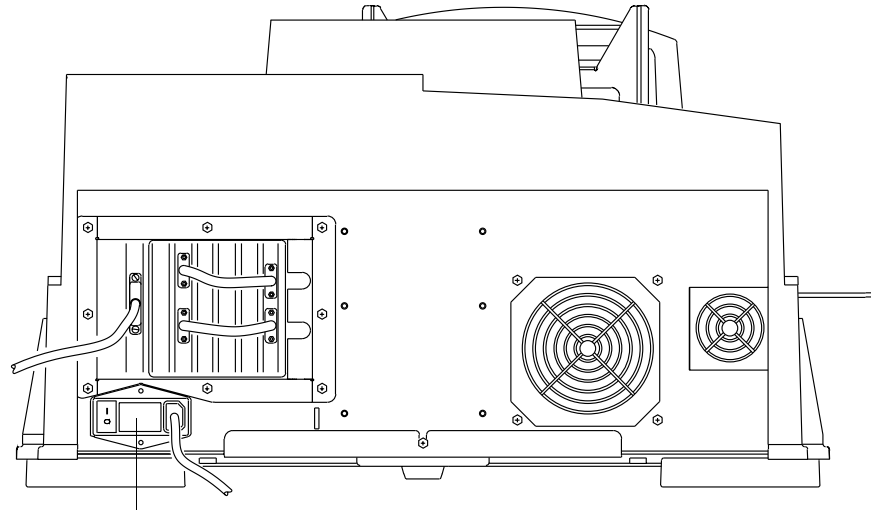

AC input module

The AC input module is factory-set to 115 V AC (60 Hz) as labeled. The accessories shipped with your scanner include two 220 V fuses (3.15 amps) to convert the scanner to 220 V operation.

If your power source is 220 or 230 V AC, verify the configuration of the AC input module. In some regions, the setting and the fuses may have been changed for you. If not, follow the procedure for *Changing the AC Input Voltage Setting and the Fuses*.

Remove the voltage sticker from the AC input module.

Changing the AC Input Voltage Setting and the Fuses

If needed, change the AC input voltage setting (voltage selector switch) and both fuses from 115 V AC to 220 V AC operation:

1. Make sure the power cord is removed from the scanner.

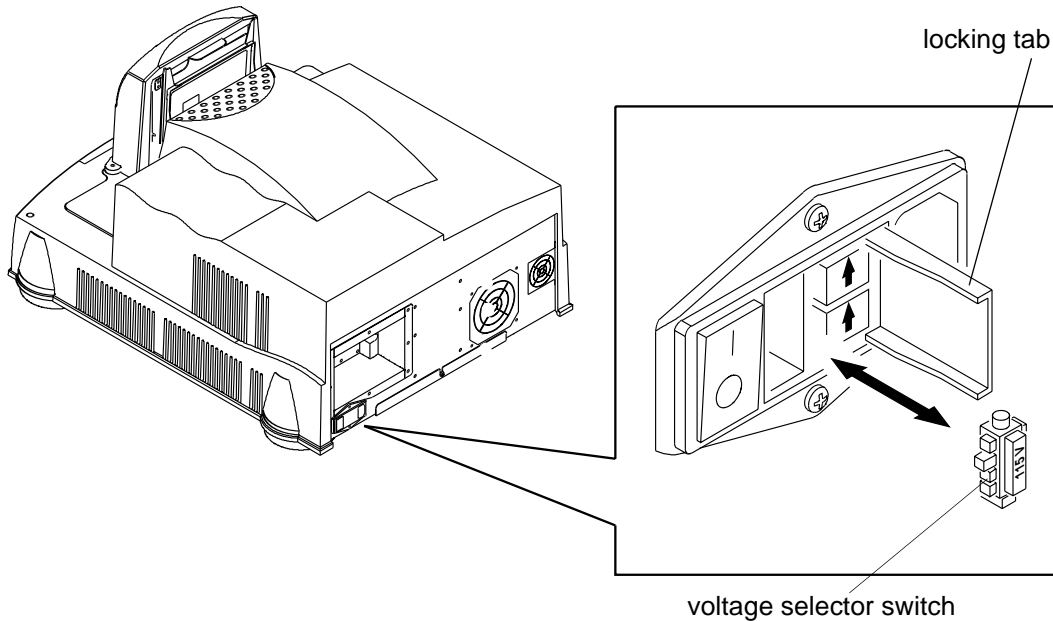

2. Insert a straight-blade screwdriver into the locking tab to open the AC input module.
3. Using your fingers (or, if needed, needle-nose pliers), remove the voltage selector switch.
4. Orient the voltage selector switch with 220 V AC facing you and insert it into the AC input module.

5. Remove the two 115 V AC (6.3 amp) fuses and replace them with the 220 V AC (3.15 amp) fuses. Make sure the arrows are pointing up.

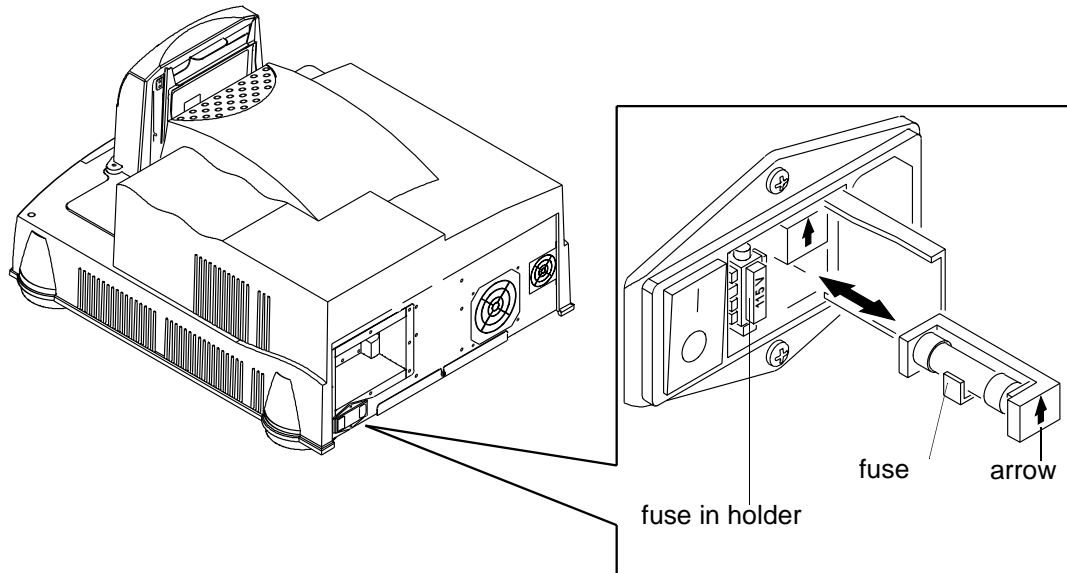

6. Close the AC input module.

Attaching the Cables

CAUTION: In the next step, avoid forcing the cable pins when plugging the cable into the scanner. You need a straight-blade screwdriver to complete the attachment of the cable to the scanner.

1. Attach the Ultra-Wide SCSI cable to the scanner and to the host computer. The host end of the cable contains ferrite beads.
2. Attach the power cable from the scanner to the power source.

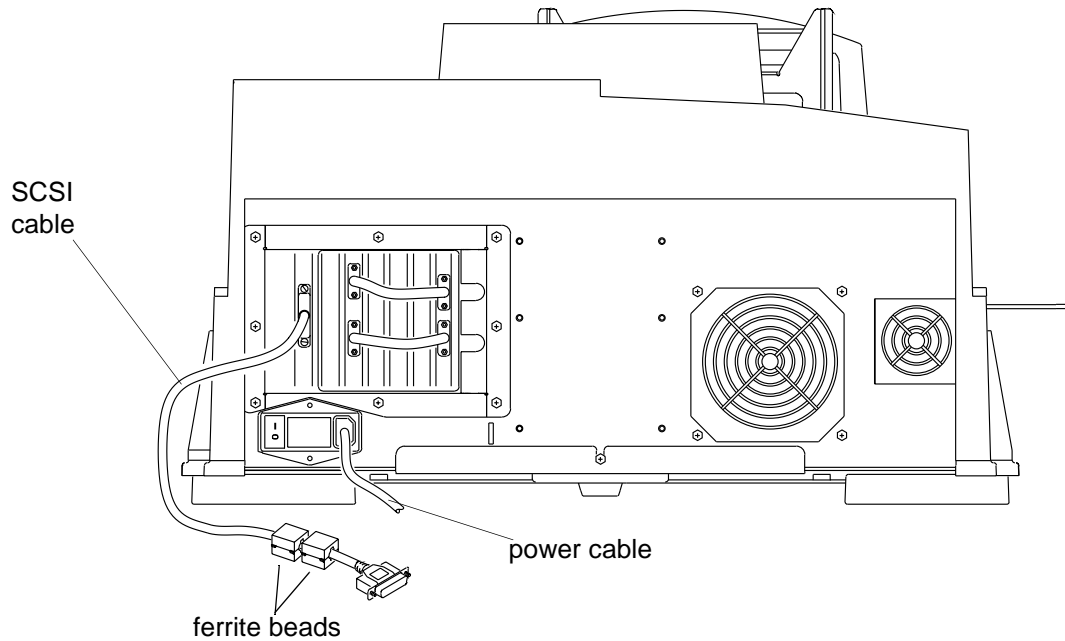

Starting Up the Scanner System

NOTE: If the scanner's power has been on and the scanner has been calibrated, continue with *Operating the Scanner* beginning on page 2-8.

IMPORTANT: Before operating the scanner in a production environment for the first time, validate that the scanner is working properly. See Chapter 3, *Validating the Scanner*.

Placing the Empty Film Holder in the Film Holder Guide

The empty "70MM-CAL" film holder must be in place in the film holder guide when you power up the scanner.

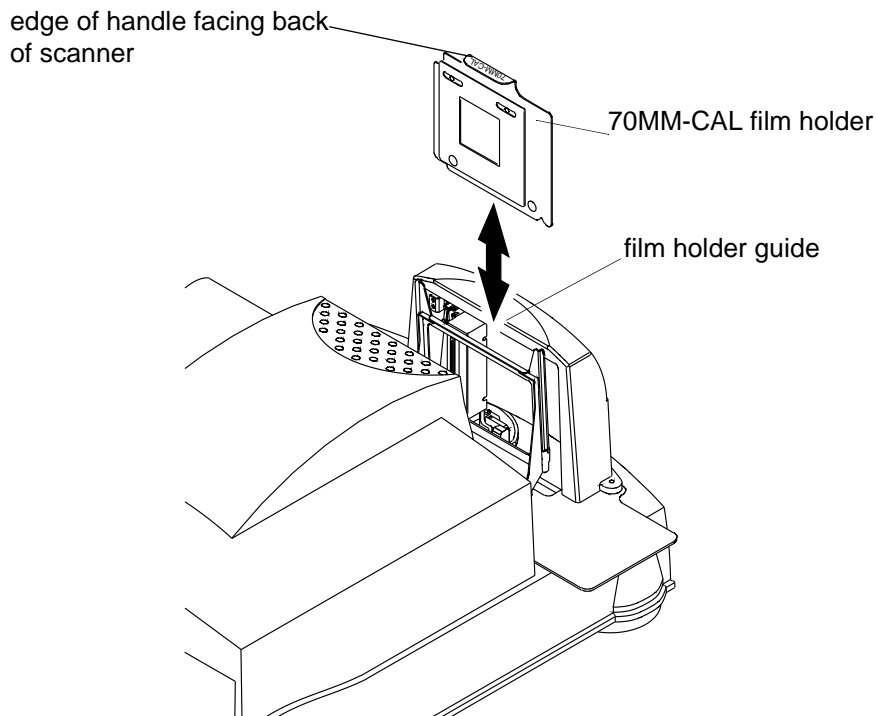

1. With the edge of the top handle facing the back of the scanner, center the film holder between the two rails of the film holder guide.
2. Lower the film holder and let it gently fall into place in the scanner.
3. With your finger, apply pressure to the handle to make sure the film holder is fully seated.

Powering up the Scanner and the Host Computer

1. Turn on the scanner's power switch.

NOTE: The green LED light on the scanner indicates only that AC power is supplied to the scanner, not that the system is ready.

Three sets of beeps will sound (first set: one beep; second set: two short beeps; third set: two short, then one long beep).

As a visual indicator that the scanner is ready, the scanner lamp lights and remains lit.

2. Turn on power to the host computer and wait until the computer desktop appears.
3. Wait 10 minutes for the lamp to warm up.

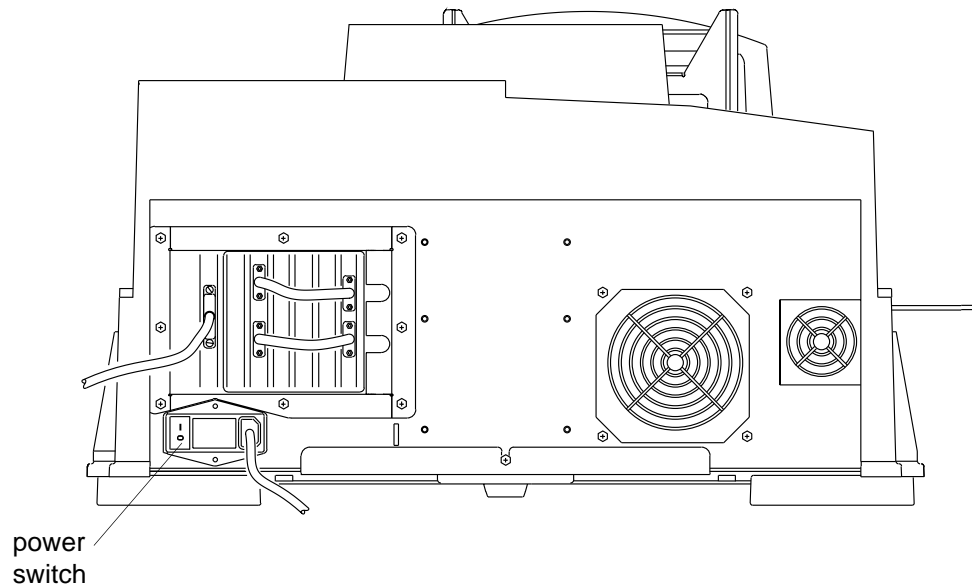

Operating the Scanner

Setting the Magnification and Calibrating the Scanner

Use your host computer's scanner software to do this procedure.

NOTE: The terminology used in your scanner software may differ from that used in this document. Refer to the software manual's instructions for performing specific operations such as calibrating the scanner and setting the magnification.

With the empty 70MM-CAL film holder in place in the scanner:

1. Set the magnification to the desired level.
2. Calibrate the scanner.

Setting the Scan Parameters

Using the software installed on your host computer, set the scan parameters, such as the area to be scanned and the file that will contain the scanned image.

Selecting the Negative or Positive Balancing Filter

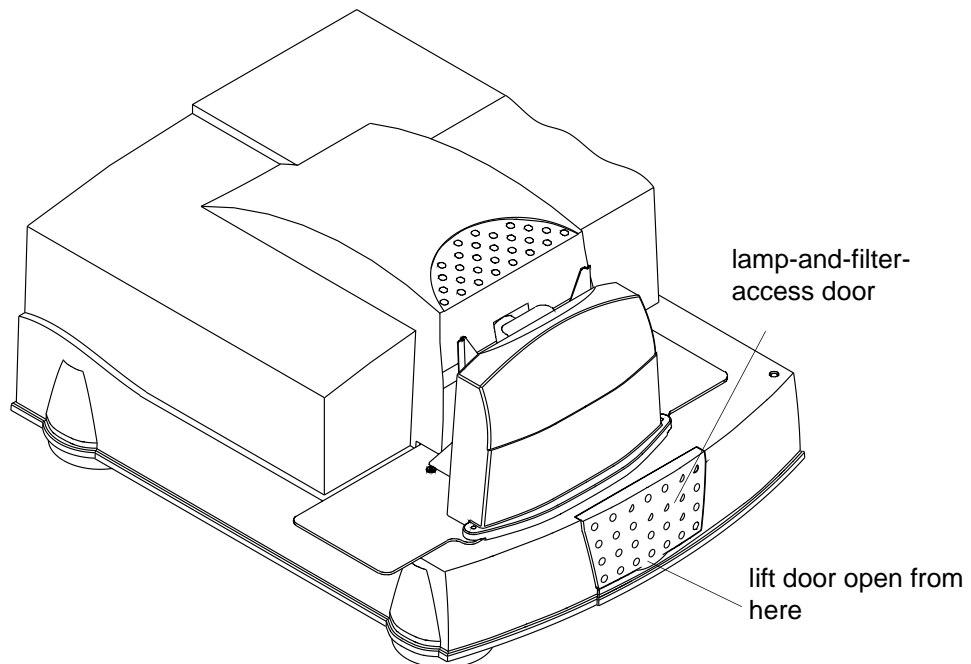

1. Lift open the lamp-and-filter-access door.

2. Make sure the red handle is in the correct position—either negative or positive—for scanning a negative or a mounted slide (positive).

IMPORTANT: If you changed the setting of the balance filter, you must calibrate the scanner before continuing. See Setting the Magnification and Calibrating the Scanner on page 2-8.

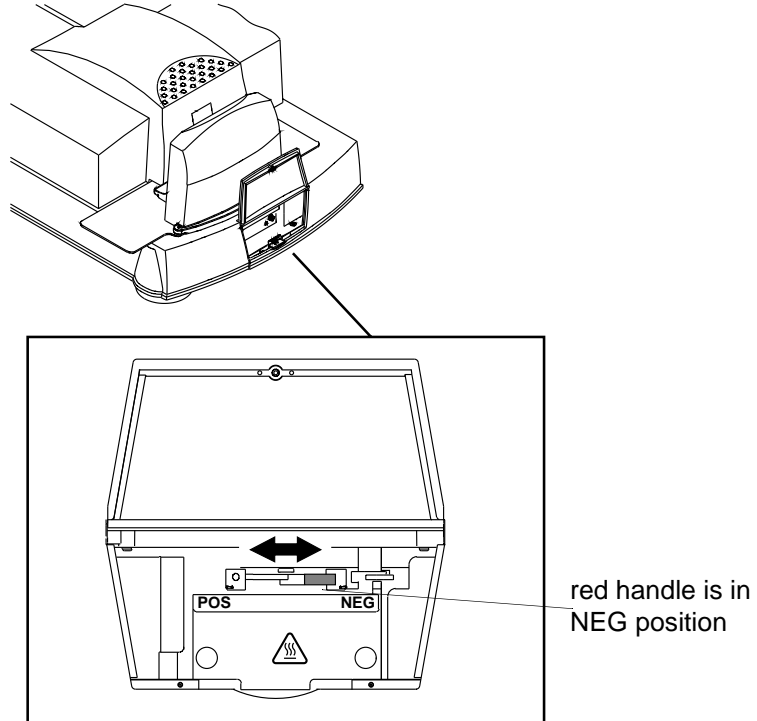

Inserting a Negative or Mounted Slide in the Scanner

Select the appropriate film holder for the negative or mounted slide you will be scanning.

Preparing a Carded Negative

IMPORTANT: For best focus, use the film holder that is closest to the size of the opening in the aperture card.

1. Lift the film holder's magnetic sheet.
2. With the emulsion side toward the rear of the scanner, locate the carded negative on the film holder's two pins.
3. Carefully close the magnetic sheet over the carded negative.

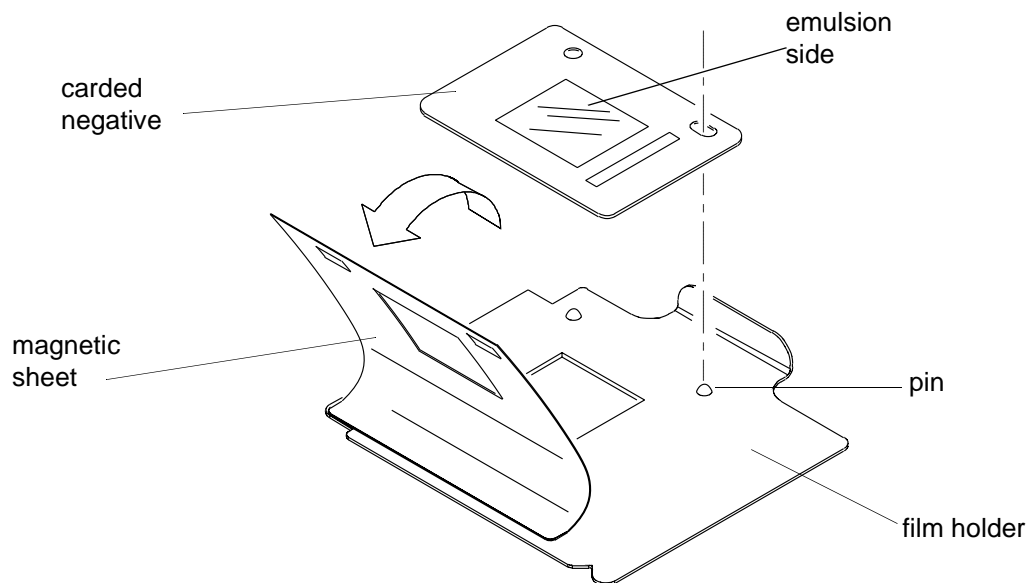

Continue with *Placing the Film Holder in the Scanner* on page 2-12.

Preparing an Uncarded Negative

Wear clean, cotton gloves when handling the negative. Illuminate the negative with a light box or hold the negative up to the light to view and align the negative.

1. Identify the emulsion side of the negative.

The emulsion side is the dull side of the negative. The printing appears backwards.

2. Select either landscape or portrait orientation.
3. Lift the magnetic sheet.
4. With the emulsion side toward the rear of the scanner, carefully align the negative over the rectangular opening in the film holder.
5. Close the magnetic sheet over the negative.

Continue with *Placing the Film Holder in the Scanner* on page 2-12.

Preparing a Mounted Slide

1. With the emulsion side toward the rear of the scanner, align the mounted slide on the film holder between the pins.
2. Carefully insert the mounted slide under the film holder's clamps and into place, keeping the slide aligned.

Placing the Film Holder in the Scanner

1. Hold the film holder guide so the top handle faces the back of the scanner. Center the film holder between the two rails of the film holder guide.
2. Lower the film holder and let it gently fall into place in the scanner.
3. With your finger, apply pressure to the handle to make sure the film holder is fully seated.

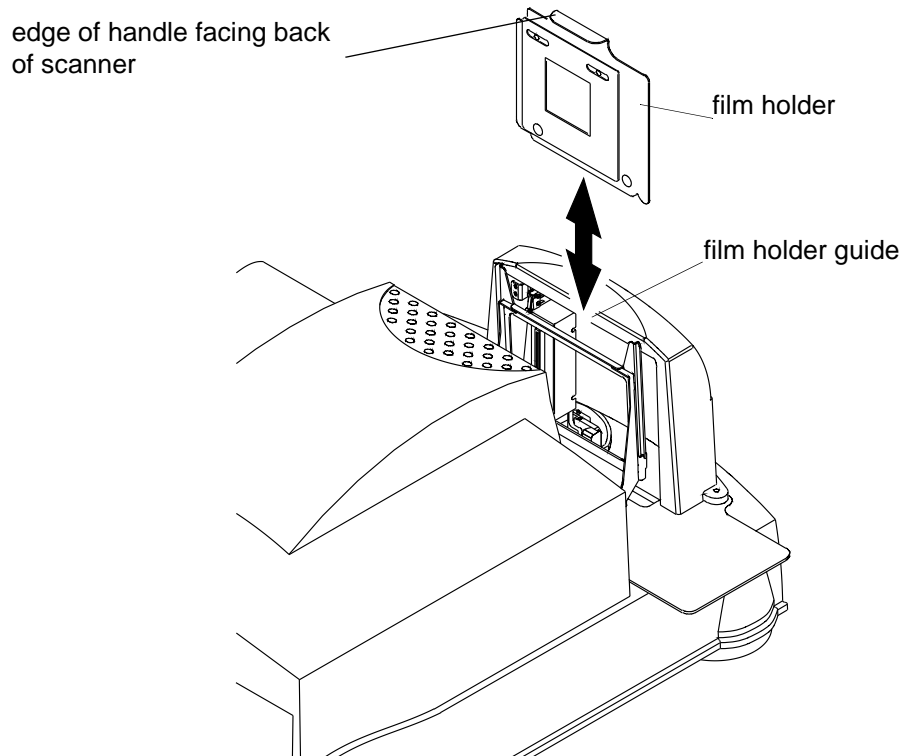

Focusing

With the negative or mounted slide installed in the scanner, use the software installed on your host computer to focus the scanner.

IMPORTANT: The need for focusing is partially dependent on the “depth of field.” When the magnification is lower—for example, 0.5—the depth of field is greater and the focus tolerance is high. As the magnification increases, the depth of field and the focus tolerance decrease. Therefore, it may be necessary to focus more frequently for higher magnifications.

Scanning a Single Frame

Using the software installed on your host computer, scan the negative or mounted slide.

Shutting Down the Scanner

Follow this procedure when you do not plan to use the scanner for extended periods of time, such as over the weekend.

1. Close the host software program and shut down the host computer.
2. Turn off power to the scanner.

3 Validating the Scanner

This chapter includes instructions for using the Service and Assembly Module (SAM) and *Adobe Photoshop* software to validate that the scanner functions properly.

NOTES: For more information about using the Service and Assembly module software on the host computer, see *Appendix A*.

Before scanning for the first time, set up a folder (on your host computer) for your work. Especially if you have more than one scanner, include the scanner serial number (on the dataplate on the back of the scanner) in the folder name.

IMPORTANT: *The empty 70MM-CAL film holder must be in position in the scanner before you start SAM. See *Placing the Empty Film Holder in the Film Holder Guide* on page 2-6.*

Starting the SAM Software

1. Open SAM. The Operations window appears with the Mag/Focus tab displayed.

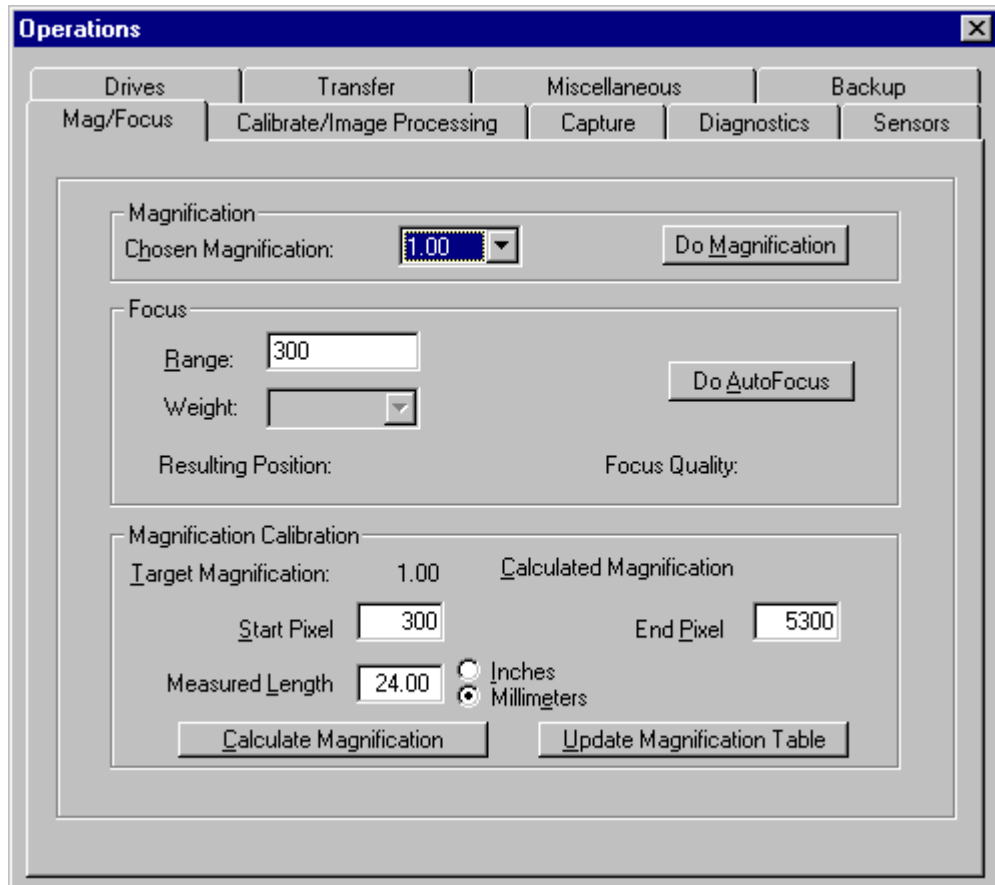

2. Perform a backup of the scanner files:
 - a. Click the Backup tab.
 - b. Click **Backup**.

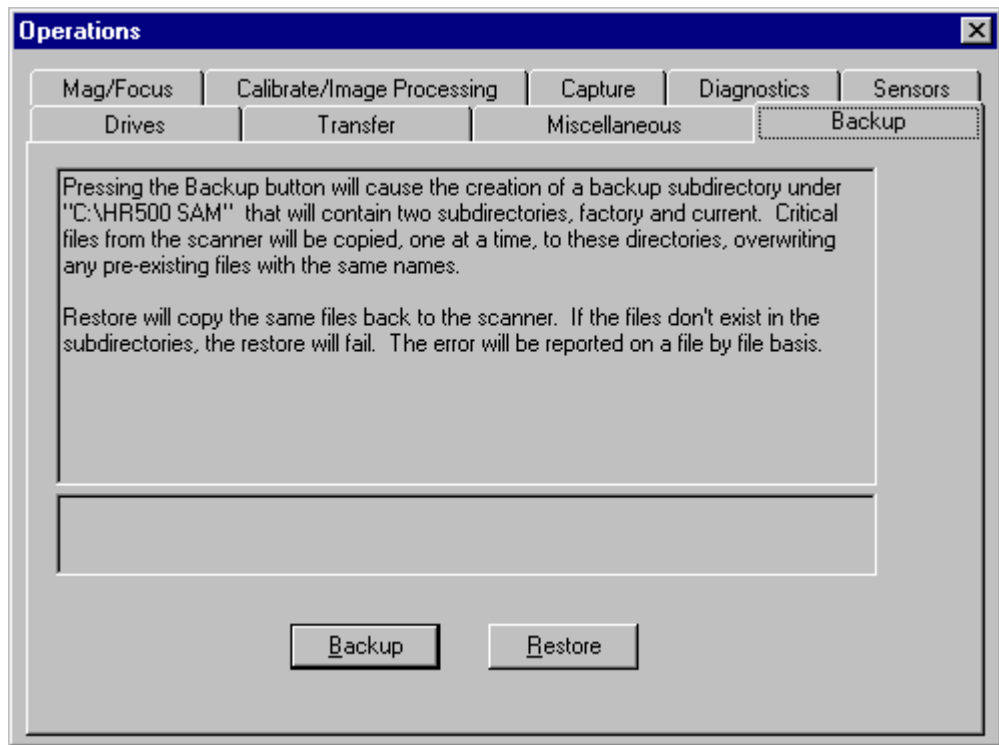

Setting the Magnification

1. Click the Mag/Focus tab.

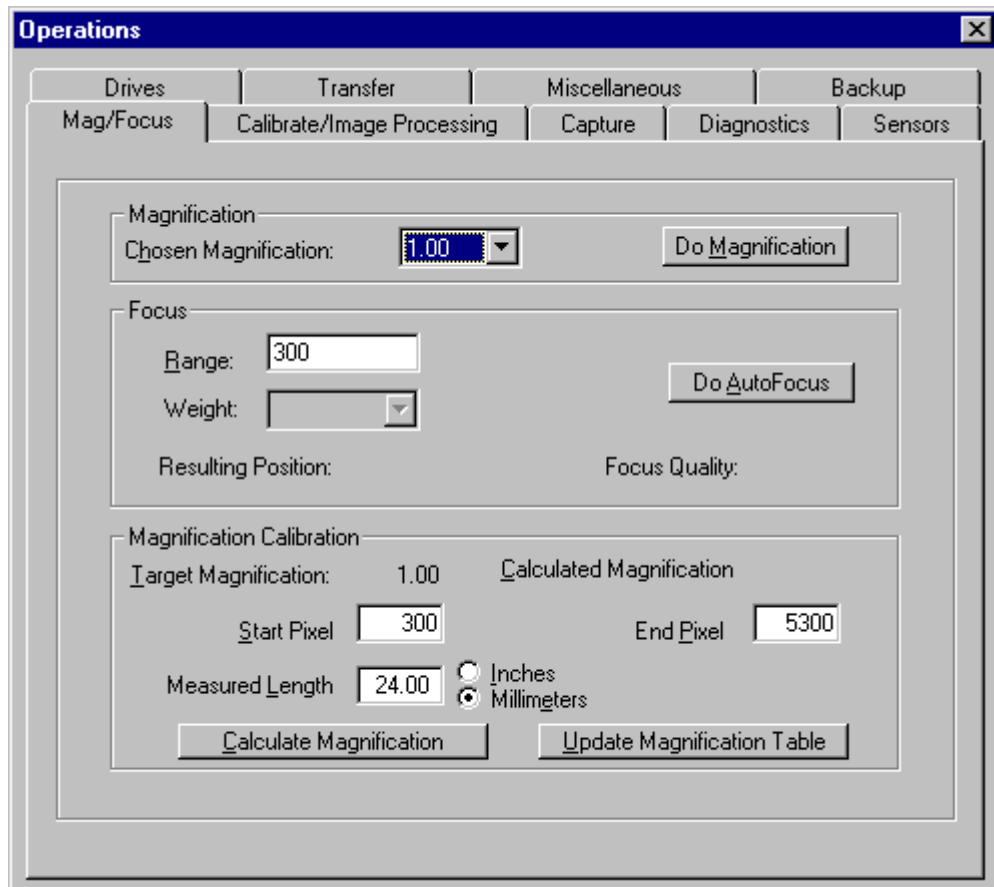

2. Select a **Chosen Magnification** of 1.00.
3. Click **Do Magnification**.
The lens moves into position.

Calibrating the Scanner

1. Click the Calibrate/Image Processing tab.

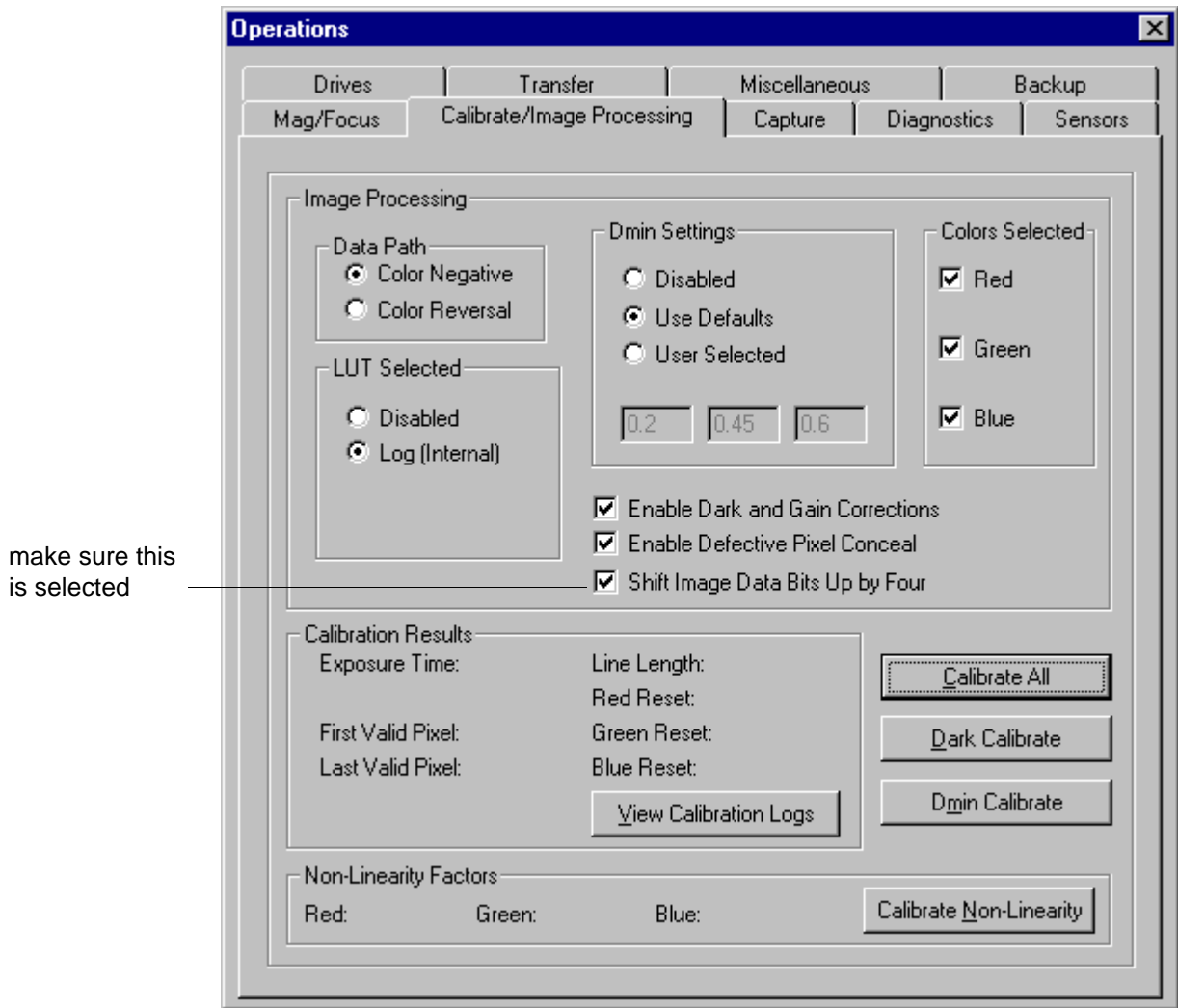

make sure this is selected

2. For the purposes of validating the scanner, make sure the values on the Calibrate/Image Processing tab match the values shown on the sample. The sample is a representation of the default values.
3. Select **Shift Image Data Bits Up by Four**.
4. Click **Calibrate All**.

Making a Test Scan

Before you scan an image, you must identify the area to be scanned and the file that will contain the scanned image.

1. Click the Capture tab.

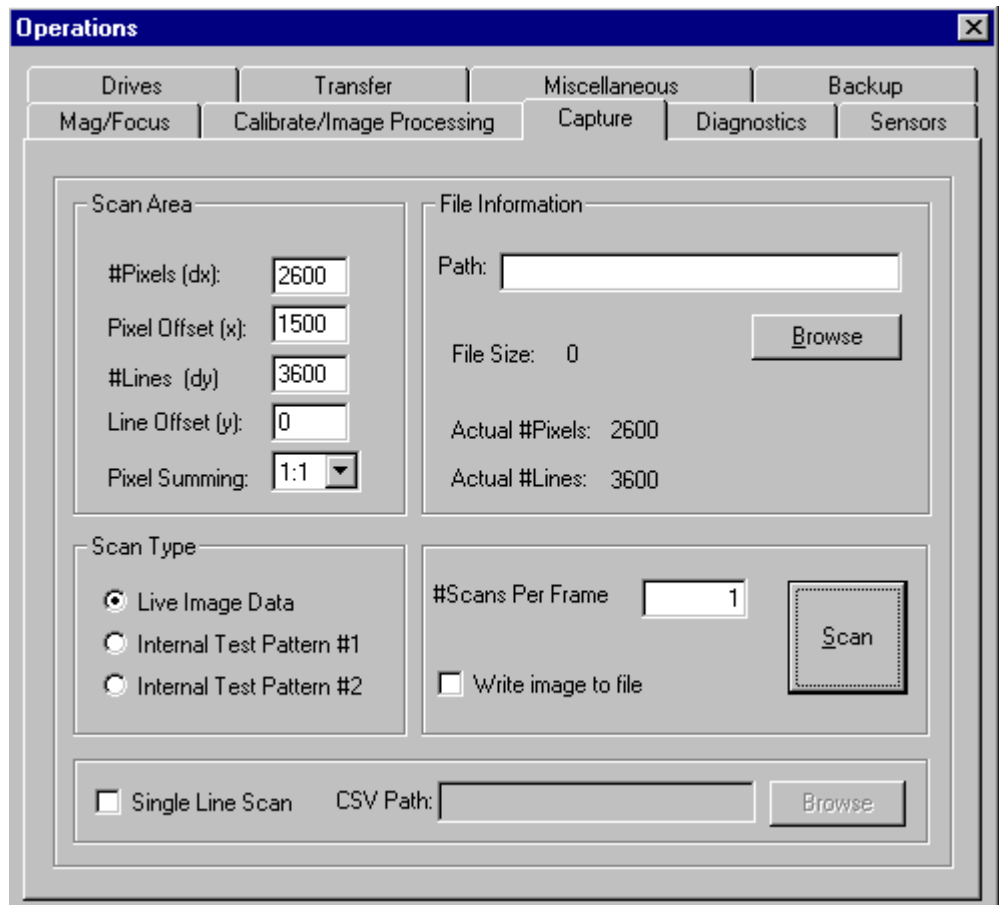

2. Enter the file information:
 - a. Click **Browse**.
 - b. Navigate to the folder for storing your images.
 - c. Click **Open** to enter the Path.
 - d. Select **Write image to file**.

3. Use the table below only as a starting point for determining **Scan Area** values.

NOTE: Keep the **Line Offset (y)**: at the default value of 0 and keep **Pixel Summing** at the default value of 1:1.

IMPORTANT: The Pixel Offset must be greater than or equal to the first calibrated pixel and # Pixels must be less than or equal to the last calibrated pixel minus the first calibrated pixel.

Cut-Gate Film Holders	Magnification	# Pixels	Pixel Offset	# Lines	File Size (MB)
35 mm double-perforated	.50	1033	2484	1460	4.3
	1.03	2129	1936	3008	18.3
	2.00	4133	934	5840	69.1
46 mm	.50	1754	2123	2554	12.8
	.60	2105	1948	3065	18.5
	1.58	5542	229	8071	128.0
6 x 4.5 cm vertical	.50	2368	1816	1539	10.4
	.66	3126	1437	2031	18.2
	1.26	5967	17	3878	66.2
6 x 4.5 cm horizontal	.50	1539	2231	2368	10.4
	.66	2031	1985	3126	18.2
	1.26	3878	1061	5967	66.2
6 x 6 cm	.50	2368	1816	2250	15.2
	.55	2605	1698	2475	18.5
	1.26	5967	17	5670	96.8
6 x 7 cm	.50	2368	1816	2775	18.8
	1.26	5967	17	6994	119.4
6 x 9 cm	.50	2368	1816	3325	22.5
	1.19	5636	182	7914	127.6
Split 70 mm	.50	2483	1759	1632	11.6
	.63	3129	1436	2056	18.4
	1.20	5960	20	3917	66.8
70 mm	.50	2682	1659	3450	26.5
	1.09	5846	77	7522	125.8
max mag	2.00	6000	0	7333	125.9
min mag	.50	2917	1542	3750	31.3

Autofocusing

1. Install a negative or mounted slide in the scanner. (See *Selecting the Negative or Positive Balancing Filter* on page 2-8.)
2. Click the Mag/Focus tab.
3. Click **Do AutoFocus**.

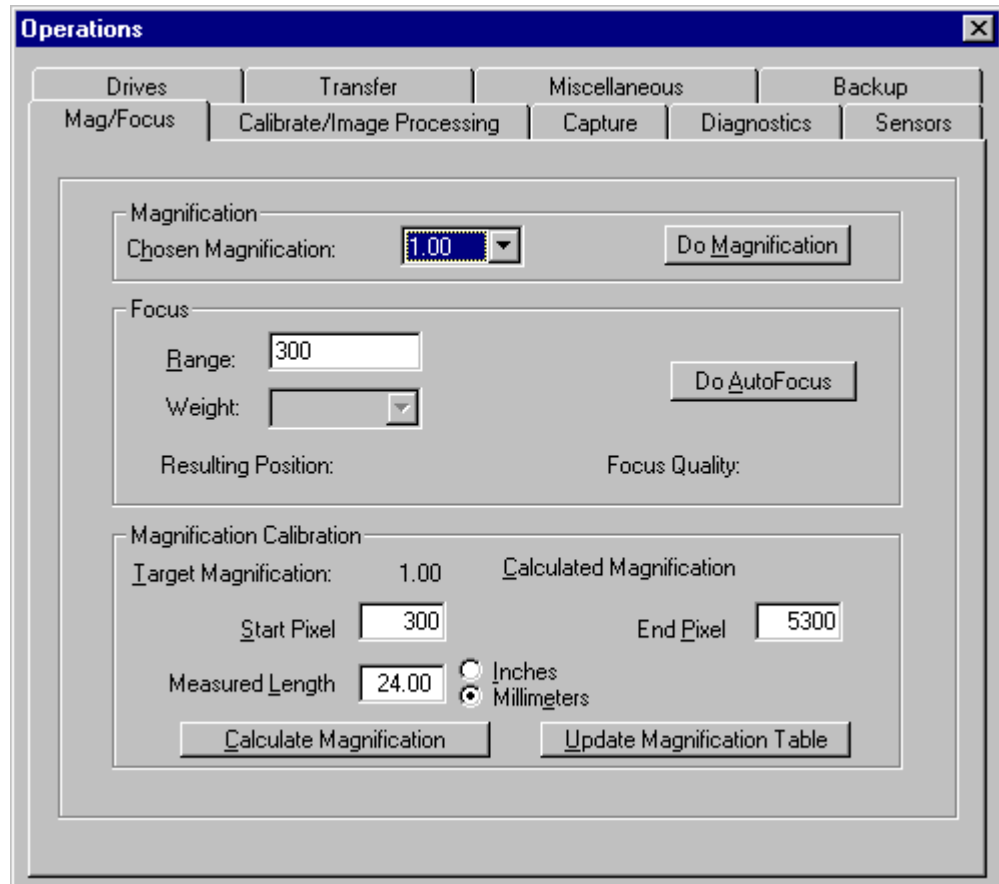

Scanning the Image

1. Click the Capture tab.
2. Click **Scan**.

Checking the Scan

1. Open *Adobe Photoshop*.
2. Select *File>Open*.
The *Windows Open* dialog appears.
3. Browse to find the file that contains the scanned image and click **Open**.
A dialog appears.
4. Enter the required values:
 - a. Enter the Dimensions:
 - **Width = Actual #Pixels** when **Pixel Summing** is **1:1**.
 - **Height = Actual #Lines** when **Pixel Summing** is **1:1**.
 - b. Enter the Channel information:
 - Set the **Count** to **3**.
 - Make sure **Interleaved** is selected.
 - Set **Depth** to **16 Bits**.
 - Set **Byte Order** to **IBM PC**.
5. Click **OK**.
After a few seconds, the raw image appears.
6. Select *Image>Adjust>Auto Levels*.
After a few seconds, a clearer image should appear.
7. Select *Image>Rotate Canvas>Flip Vertical*.
NOTE: You may also need to select *Image>Rotate Canvas>90° CCW*.
8. Check that the image appears as you expected.
9. If the image does not appear as you expected, repeat this procedure, making sure you follow the instructions exactly. Then if you still do not get the expected results, contact your Kodak representative.

4 Maintaining the Equipment

This chapter contains procedures to be done by the person who is responsible for maintenance of the *Kodak Professional HR 500 Film Scanner*.

Items required for maintenance are:

- Kodak camel's-hair brush (provided)
- dry, untreated microfiber cleaning cloth
- lint-free cloth
- white cotton gloves
- Phillips-head screwdriver

Cleaning Procedures

To minimize the need for cleaning the scanner and to reduce the possibility of artifacts, make sure your scanner is in a clean, low-traffic area that does not collect a lot of dust. Wood, tile, linoleum, or sealed concrete floors are preferable to carpet.

Clean the surface of the scanner with a damp lint-free cloth as needed.

IMPORTANT: Please read the following before performing any cleaning procedures.

Avoid using pressurized air or canned air near the scanner.

If it is necessary to use canned air to clean film, direct the air stream away from the scanner.

Instructions for cleaning the balance and IR filters are included under *Replacement Procedures* beginning on page 4-4.

IMPORTANT: The balance and IR filters are made of glass and are expensive to replace. They are not included in the product warranty or service contract. Use care when handling the balance and IR filters.

When you remove the filters, inspect them. Cleaning may be all that is required. Otherwise, replace the filters as needed.

Cleaning the Lens

IMPORTANT: *Wear white cotton gloves for this procedure to prevent oils and dirt from being absorbed into the microfiber cleaning cloth.*

1. Use the software installed on your host computer to set the magnification to 2.00, which positions the lens as near to the front of the scanner as possible.
2. Clean the front of the lens with the supplied camel's-hair brush.
3. Check that the lens is clean; if not, clean with a dry, untreated microfiber cleaning cloth.

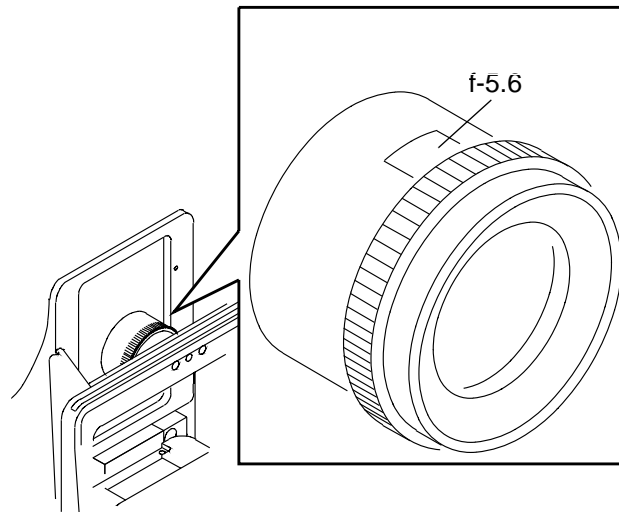

4. Check that the lens is set to f-stop setting f-5.6.

Cleaning the Light Bar

If artifacts appear on your scanned images, clean the light bar.

IMPORTANT: Wear white cotton gloves for this procedure to prevent oils and dirt from being absorbed into the microfiber cleaning cloth.

1. Fold a dry, untreated microfiber cleaning cloth so the edge of the cloth is about the thickness of the light bar.

NOTE: You can use an *e-wipe*, manufactured by Photographic Solutions, Inc., instead of a microfiber cleaning cloth.

2. Gently move the edge of the microfiber cloth or *e-wipe* down the length of the light bar one time.
3. Calibrate the scanner.
4. If an artifact remains after cleaning the light bar, check the light bar with a magnifying glass for damage, such as a scratch or a chip. If there is damage to the light bar, contact your Kodak representative for service.

Replacement Procedures

Replacing the Lamp

White cotton gloves are required for this procedure.

One spare lamp is provided with the scanner.

IMPORTANT: Use only the GE ELC Lamp with the HR 500 Film Scanner (see Appendix B: Ordering Accessories and Supplies).

It is not necessary to power down the scanner before changing the lamp.

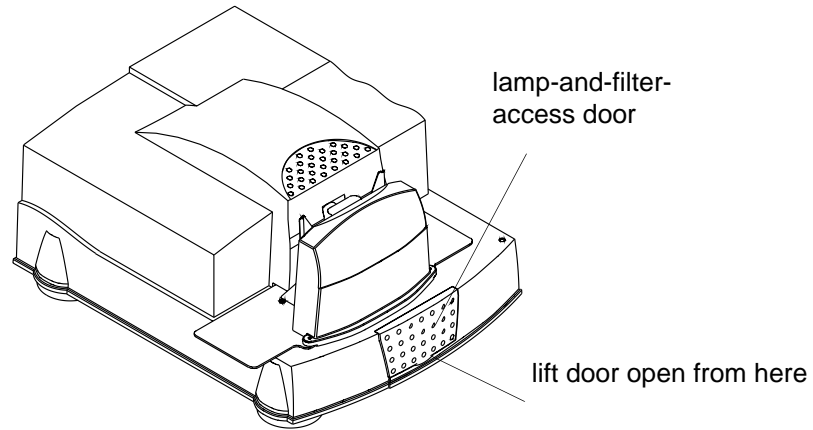

1. Open the lamp-and-filter-access door.

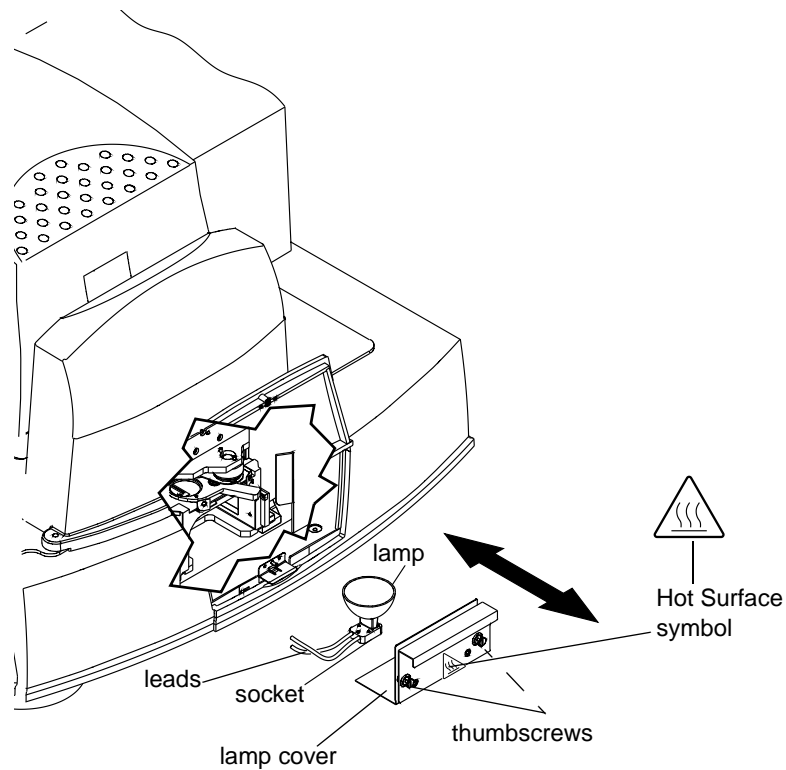

2. Loosen the thumbscrews on the lamp cover and pull the cover straight out.
When you remove the cover, the safety switch is released, removing power to the lamp socket.

CAUTION: Wait at least five minutes for the lamp to cool.

3. Push down the lamp release lever.
4. Remove the old lamp from the lamp socket.
5. Fully seat the new lamp in the socket; polarity is not important.

CAUTION: In the next step, to ensure correct alignment with the light bar, it is extremely important to push the lamp to the back of the lamp holder with the leads facing to the left. Improper alignment affects the operation of the scanner.

6. With the socket leads facing left, reinstall the lamp in the lamp holder.
7. Reinstall the lamp cover and tighten the thumbscrews.

Power is reapplied to the lamp socket and the lamp should light.

8. Calibrate the scanner (see *Calibrating the Scanner* on page 3-4).

Replacing the (Round) Balance Filters

IMPORTANT: The balance filters are made of glass and are expensive to replace. They are not included in the product warranty or service contract. Use care when handling the balance filters.

Wear white cotton gloves for this procedure.

It is not necessary to power down the scanner before changing the balance filters.

1. Open the lamp-and-filter-access door (see page 4-4 for the location of the lamp-and-filter-access door).

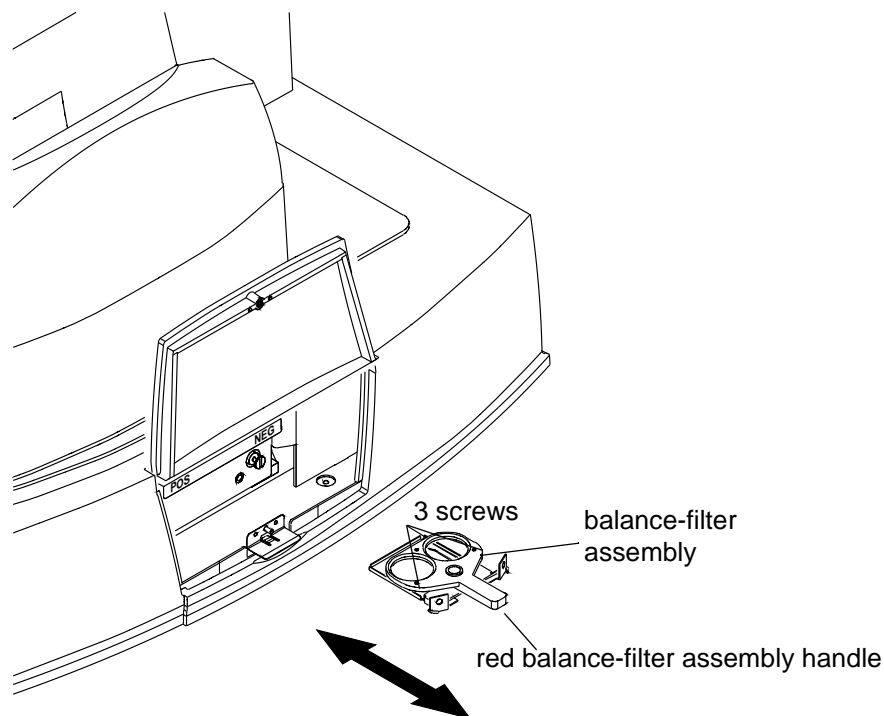

2. Loosen the thumbscrews on the lamp cover and pull the cover straight out.
When you remove the cover, the safety switch is released, removing power to the lamp socket.

CAUTION: Wait at least five minutes for the lamp to cool.

3. Position the red balance-filter selection handle of the balance-filter assembly in the center.

CAUTION: Use care with the IR filter. It is not secured in place. (For more information about the IR filter, see *Replacing the (Square) IR Filter* on page 4-8.)

4. Hold the red handle and pull the assembly straight out from the scanner.
5. Clean the filters with the camel's-hair brush or, if needed, replace the filter(s) as described in the next step.
6. Replace the balance filters:
 - a. Remove the 3 screws.
 - b. Remove the filter retainer.
 - c. Remove the old filters and place the new filters in the filter holder.
The filters are coated on both sides. It is not important which side faces up or down.
 - d. Secure the filters with the retainer and the 3 screws.
7. Install the filter assembly in the scanner with the balance-filter selection handle in the middle.
8. Reinstall the lamp cover, tighten the thumbscrews, and select a filter position.
9. Calibrate the scanner (see *Calibrating the Scanner* on page 3-4).

Replacing the (Square) IR Filter

IMPORTANT: The IR filter is made of glass and is expensive to replace. It is not included in the product warranty or service contract. Use care when handling the IR filter.

Wear white cotton gloves for this procedure.

It is not necessary to power down the scanner before changing the IR filter.

1. Open the lamp-and-filter-access door (see page 4-6 for the location of the lamp-and-filter-access door).

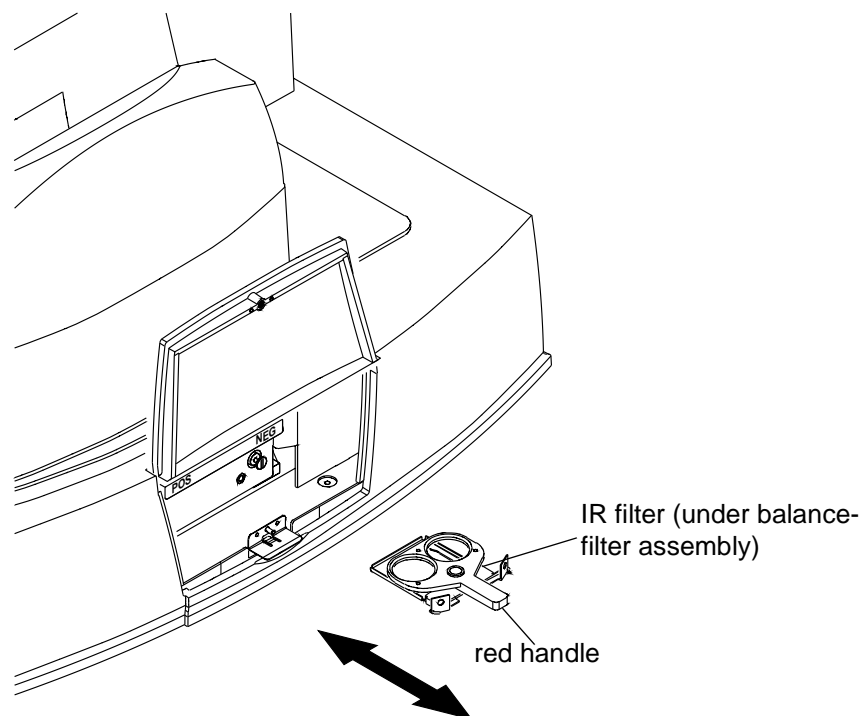

2. Loosen the thumbscrews on the lamp cover and pull the cover straight out.
When you remove the cover, the safety switch is released, removing power to the lamp socket.

CAUTION: Wait at least five minutes for the lamp to cool.

3. Position the red balance-filter selection handle of the balance-filter assembly in the center.
4. Hold the red handle and pull the assembly straight out from the scanner.
5. Push the IR filter up from below the filter assembly.
6. Clean the IR filter with the camel's-hair brush or, if needed, replace the IR filter as described in step 7.

CAUTION: Use care with the IR filter. It is not secured in place.

7. If replacing the IR filter, set the new filter in place with the arrows on the edges of the filter pointing down toward the scan lamp.
8. Install the filter assembly in the scanner with the balance-filter selection handle in the middle.
9. Reinstall the lamp cover, tighten the thumbscrews, and select a filter position.
10. Calibrate the scanner (see *Calibrating the Scanner* on page 3-4).

Appendix A: Using the Service and Assembly Module (SAM)

The Service and Assembly Module (SAM) software performs many of the same functions as other host software. Its primary purpose for users is to validate that your scanner is working correctly and to allow you to perform simple scan functions. There are also service and diagnostics functions that should be used only with the assistance of a Kodak service representative.

Functions supported by the SAM software are:

- setting a magnification
- calibrating the scanner
- setting the image processing mode (negative or positive)
- autofocusing at any given magnification
- defining the area to be scanned
- scanning and transferring images from the scanner to the host computer
- performing miscellaneous features such as:
 - turning the lamp on and off
 - resetting the lamp-on timer
 - rebooting the scanner
 - retrieving scanner usage information
 - displaying software version information
- backing up and restoring critical scanner files

Installing the Service and Assembly Module (SAM) Software

1. Load the SAM CD.
2. Run **setup.exe** from the SAM CD.
3. Respond to the prompts in the installation program.
You must provide the program location and the name of the program menu item.
4. When installation is complete, reboot your host computer.
5. Remove the CD and store it in a safe place.

Backing Up Scanner Files

IMPORTANT: It is essential that you back up the scanner files before using SAM.

1. Open SAM.
2. From the Operations window, click the Backup tab.
3. Click **Backup** to back up the critical scanner files.

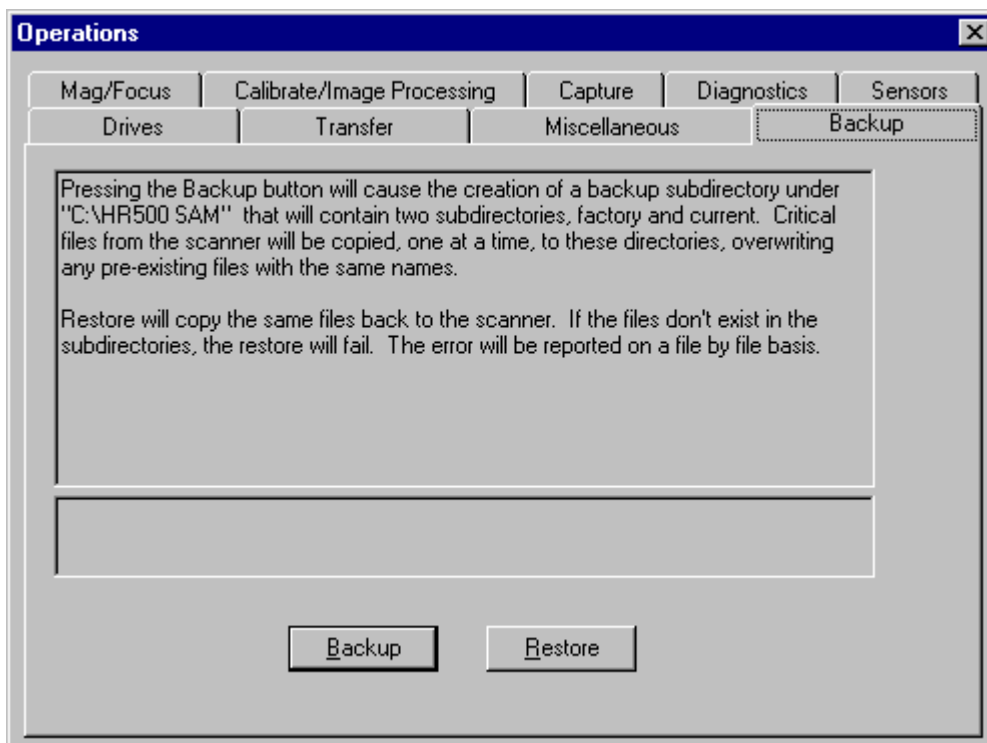

Using the Operations Controls

If the Operations window does not appear, select *View->Operations Controls*.

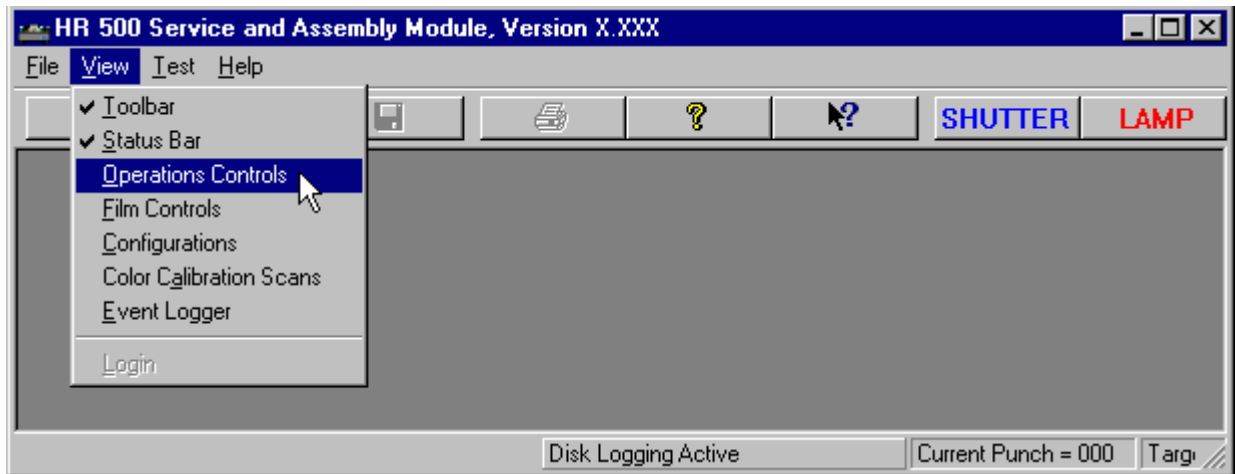

IMPORTANT: The Diagnostics, Sensors, Drives, and Transfer tabs are not needed for user functions. Use these tabs only at the request of your Kodak support representative.

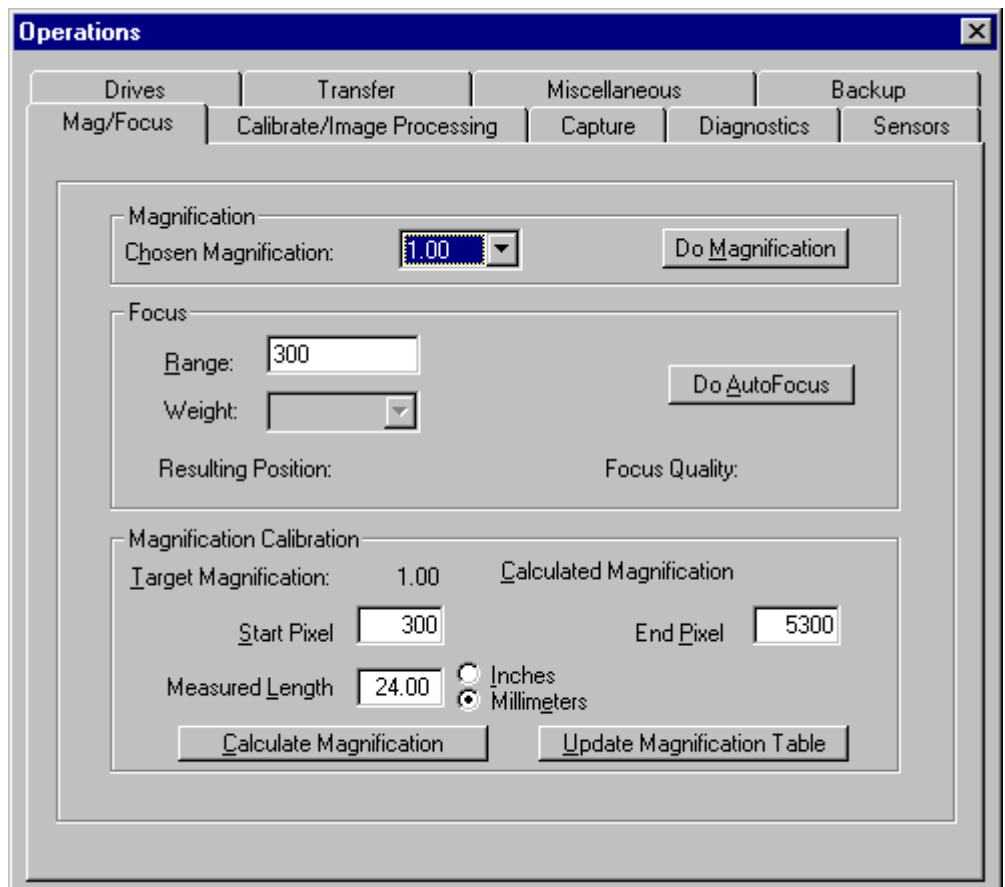

Performing the Functions on the Mag/Focus Tab

IMPORTANT: Magnification Calibration should be done only with the guidance of a Kodak support representative.

From the Operations window, click the Mag/Focus tab when you need to set the magnification (position of the lens) or do an autofocus.

The screenshot shows the 'Operations' window with the 'Mag/Focus' tab selected. The window has a title bar with 'Operations' and a close button. Below the title bar are several tabs: 'Drives', 'Transfer', 'Miscellaneous', 'Backup', 'Mag/Focus', 'Calibrate/Image Processing', 'Capture', 'Diagnostics', and 'Sensors'. The 'Mag/Focus' tab is active and contains three main sections:

- Magnification:** A 'Chosen Magnification' dropdown menu is set to '1.00'. A 'Do Magnification' button is to the right.
- Focus:** A 'Range' text box contains '300'. A 'Weight' dropdown menu is empty. A 'Do AutoFocus' button is to the right. Below these are labels for 'Resulting Position:' and 'Focus Quality:'.
- Magnification Calibration:** A 'Target Magnification' text box contains '1.00'. A 'Calculated Magnification' text box is empty. A 'Start Pixel' text box contains '300' and an 'End Pixel' text box contains '5300'. A 'Measured Length' text box contains '24.00'. There are two radio buttons: 'Inches' (unselected) and 'Millimeters' (selected). Below these are 'Calculate Magnification' and 'Update Magnification Table' buttons.

Setting the Magnification

1. On the Mag/Focus tab, select the **Chosen Magnification**. The value can be between 0.5 and 2.0.

The scanner's software maintains an internal Mag/Focus position table that associates a motor position for each of the possible magnification values.

2. Click **Do Magnification**.

The lens and CCD move to the chosen position.

Performing an Autofocus

1. On the Mag/Focus tab, enter the Focus **Range**. The recommended value is 300. The Range is the initial range of travel used for the CCD and lens, in motor steps.

NOTE: To make the focus procedure faster: if you have focused on a given magnification, you can set the Range value to be less than 300.

IMPORTANT: Autofocus will be done for the Chosen Magnification. It is assumed that when you do an Autofocus, you have:

- *calibrated with an empty film holder (see Calibrating the Scanner on page A-7)*
- *placed the film to be scanned in the scanner (see Inserting a Negative or Mounted Slide in the Scanner on page 2-10)*
- *set the scan area (see Using the Capture Tab on page A-8); for fastest scanning, set the # of pixels (in the Scan area) to 1000*

2. Click **Do AutoFocus**.

Performing the Functions on the Calibrate/Image Processing Tab

From the Operations window, click the Calibrate/Image Processing tab when you need to calibrate the scanner.

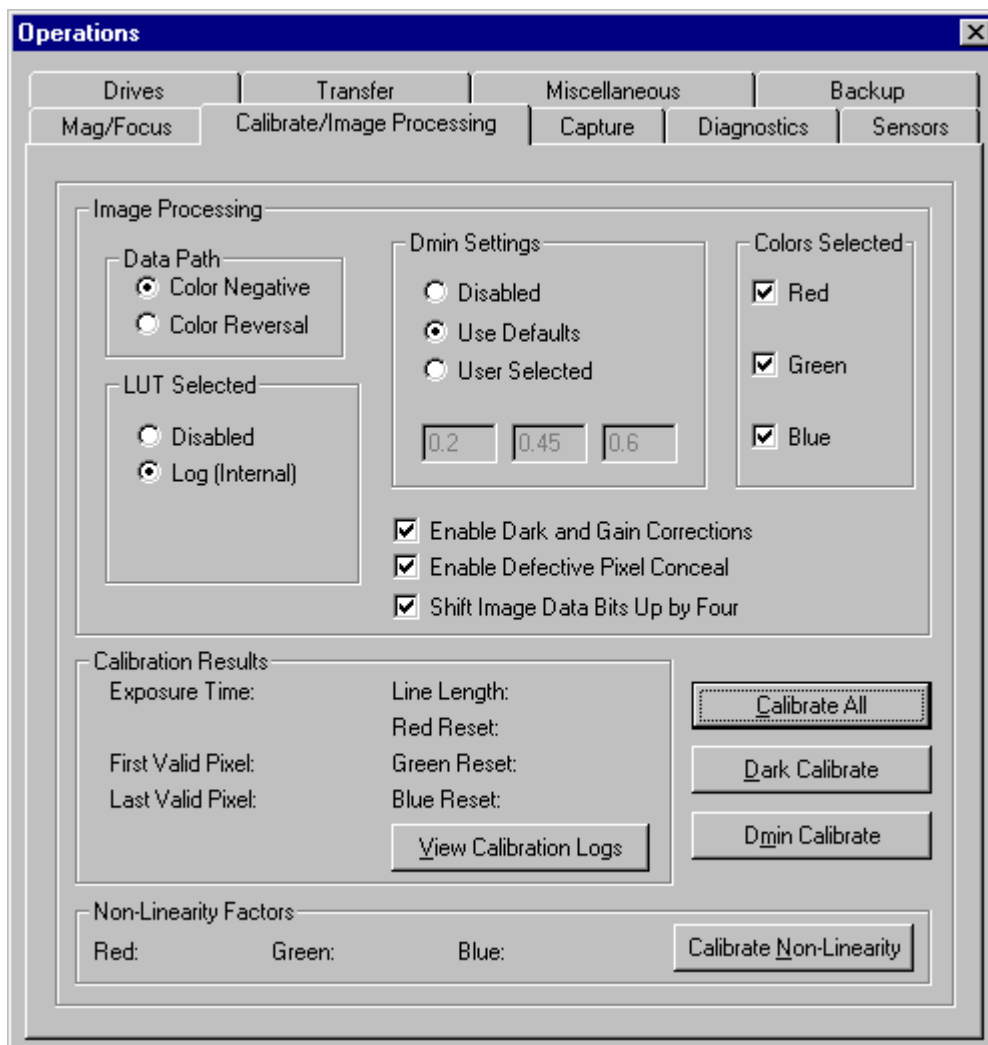

Setting Image Processing Parameters

1. Select the **Data Path**.
2. Select the **LUT Selected**.
3. Select the **Dmin Settings**.
4. Select the **Colors Selected**.
5. Select:
 - **Enable Dark and Gain Corrections**
 - **Enable Defective Pixel Conceal**
 - **Shift Image Data Bits Up by Four**

Calibrating the Scanner

*IMPORTANT: The 70MM-CAL film holder must be in position in the scanner before you continue. See *Placing the Empty Film Holder in the Film Holder Guide* on page 2-6.*

1. If the values on the Calibrate/Image Processing tab do not match the values shown on the sample on page A-6, change them. The sample is a representation of the default values.
2. Select **Shift Image Data Bits Up by Four**.
3. Click **Calibrate All**.

Using the Capture Tab

From the Operations window, click the Capture tab when you need to perform a scan.

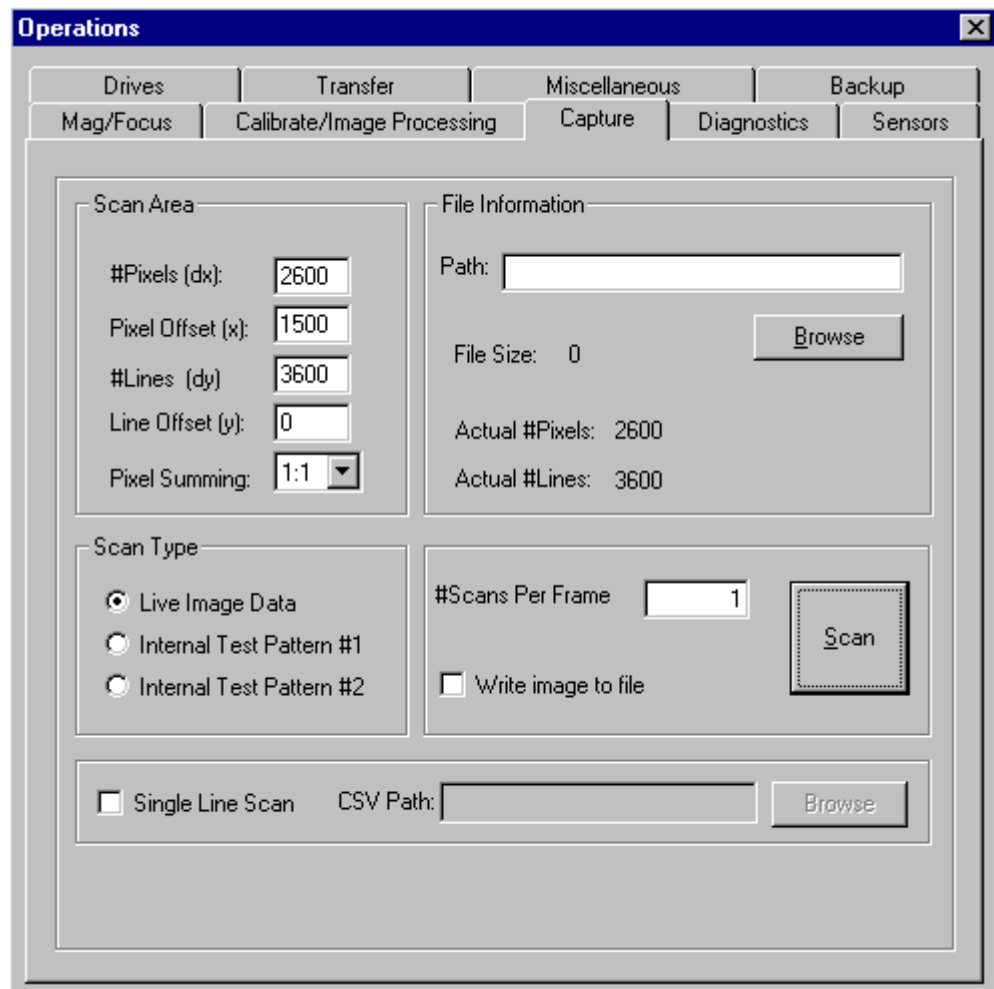

Setting the Scan Area

To set the Scan Area, enter values for:

- **# Pixels** (valid values range from 1 through 6002); for fastest scanning, enter a value of 1000
- **Pixel Offset** (valid values range from 0 through 6001)
- **# Lines** (valid values range from 1 through 7464)
- **Line Offset** (valid values range from 0 through 7463)
- **Pixel Summing** (valid values are 1:1, 1:2, and 1:4)

NOTE: If you select **Pixel Summing** of 1:2 or 1:4, use the **Actual #Pixels** and **Actual #Lines** for viewing the image in the *Adobe Photoshop* program.

Scanning the Image Data

1. If desired, save the scanned image as a file:
 - a. Enter the Path information (file destination).
 - b. Select **Write image to file**.
2. Click **Scan**.

Using the Miscellaneous Tab

Clicking the Miscellaneous tab on the Operations window lets you:

- turn the lamp on and off
- reset the lamp timer to zero
- reboot the scanner
- initialize the scanner
- get the scanner time
- get scanner usage information
- get scanner attributes
- get version information

Click the appropriate button to perform the corresponding function.

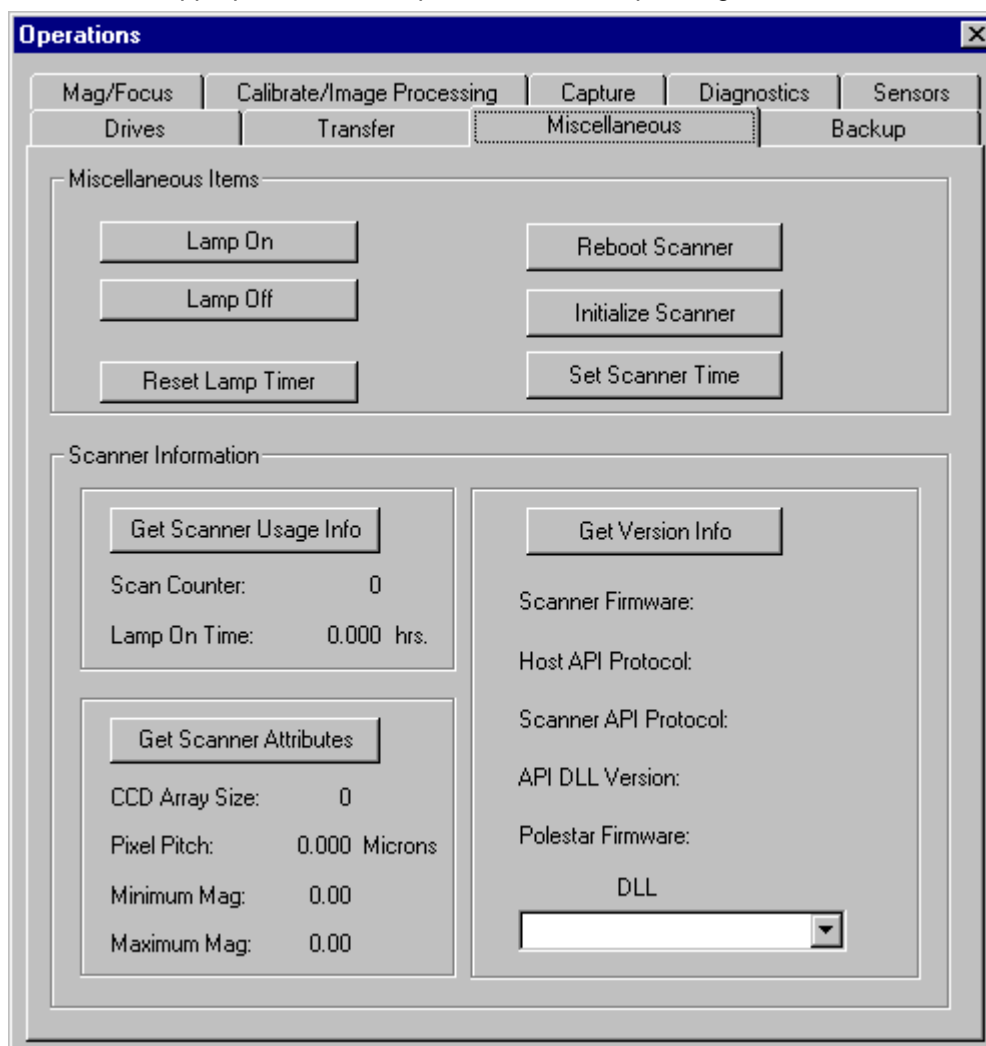

Backing Up and Restoring Files

From the Operations window, click the Backup tab when you need to perform either a backup or restore of the scanner files.

- Click **Backup** to back up scanner files.

CAUTION: Use Restore only when recommended by a Kodak support person.

- Click **Restore** to copy backed up files to the scanner.

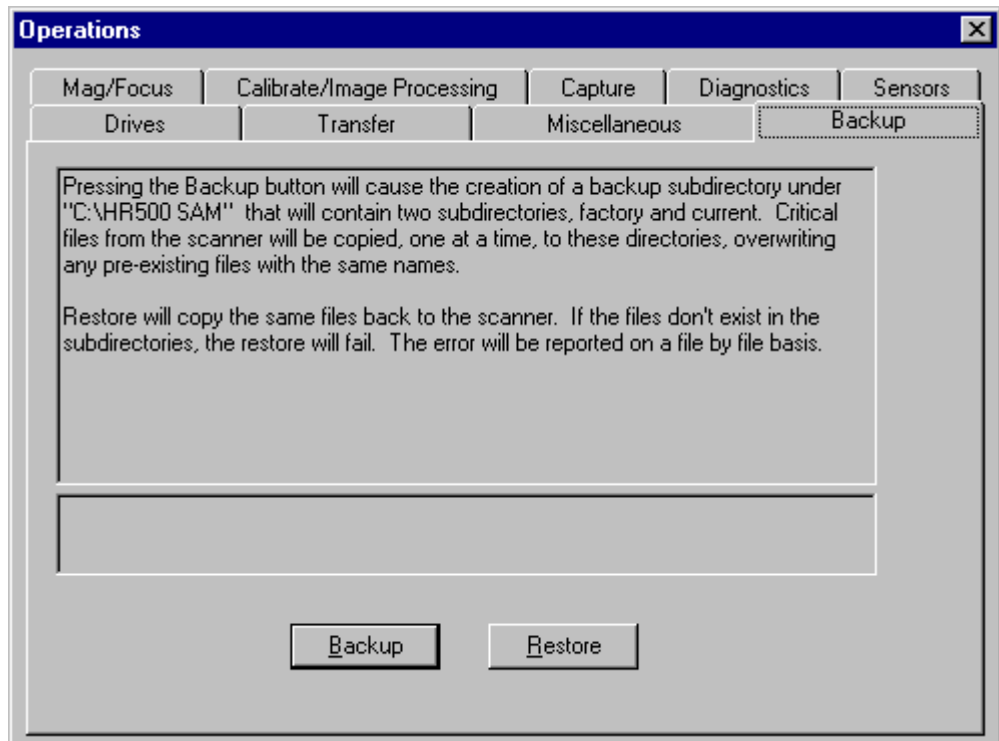

Appendix B: Ordering Accessories and Supplies

Accessories

<i>Item Description</i>	<i>Order Number</i>
Manual: Operator's Guide for the <i>Kodak Professional</i> HR 500 Film Scanner	6B6377
<i>Kodak Professional</i> HR 500 Scanner Long Roll Accessory	158 5496
<i>Kodak Professional</i> HR 500 35mm Scanner Strip Gate Accessory	843 0316
<i>Kodak Professional</i> HR 500 Scanner 120 Strip Gate Accessory	844 0554
<i>Kodak Professional</i> HR 500 Film Holders	890 7776

Recommended Accessories

<i>Item Description</i>	<i>Order Number</i>
Static Elimination Kit Available from: Holter Associates, Inc. 1170 Pittsford-Victor Road, Pittsford, NY 14534 Phone: (716) 381-7988; Fax: (716) 381-2351	
115 V Kit – Static Elimination Kit	2RSM80-115
230 V Kit – Static Elimination Kit	2RSM80-230
Super Film Cleaner or an equivalent cleaner with ionized air and particle transfer rollers (PTR) Super Film Cleaner is available from: Brooke International P.O. Box 300 Hansville, WA 98340-0300 Phone: (360) 638-2591; Fax: (360) 630-1658	

Supplies

<i>Item Description</i>	<i>Order Number</i>
GE ELC Lamp	106 3189
Microfiber Cleaning Cloths	980 4014
<i>e-wipes</i> Available from: Photographic Solutions, Inc. Phone: (800) 637-3212; Fax: (508) 759-9699	

Appendix C: Scanner Specifications

Site Specifications	
AC Power Requirements	1,750 watts peak
AC Frequency	50 or 60 Hz
AC Phase	Single
Operating Environment	Room temperature: 65 to 80° F (18 to 27° C) Relative humidity: 20 to 70% Ambient light: less than 1000 lux; no exposure to direct lighting Altitude: 7000 feet (2134 m) maximum

Scanner Specifications																						
Dimensions and Weight	Height: 15 in. (38,1 cm) Width: 24 in. (61 cm) Depth: 30 in. (76,2 cm) Weight: 120 lbs (54,5 kg) Footprint: 5 square feet																					
Operating and Service Clearances	Rear: 1.5 feet (45,7 cm) for operation, 3 feet (91,4 cm) for service Sides: 2 feet (60 cm) for operation and service Front: 4 feet (122,9 cm) for operation and service																					
Scanner Location	<p>The scanner location relative to the host workstation is limited by the SCSI interface cable length; if you are using a cable stocked by Kodak, this distance is 2 meters or less. Longer cables are not supported for use with the scanner. The scanner must be the only SCSI device attached to the host computer.</p> <p>The scanner should be located on a table that:</p> <ul style="list-style-type: none"> • is stable • can support approximately 120 lbs (54,5 kg) • is at least 30 in. (76,2 cm) long x 30 in. (76,2 cm) wide 																					
Power Consumption and Thermal Load	Power Consumption: 425 watts maximum; 400 watts typical Thermal Load: 1325 BTU operating; 1230 BTU standby																					
AC Voltage and Current Draw	<table> <tbody> <tr> <td>100 V AC/50 Hz</td> <td>4.2 amps operating;</td> <td>3.9 amps standby</td> </tr> <tr> <td>100 V AC/60 Hz</td> <td>4.1 amps operating;</td> <td>3.85 amps standby</td> </tr> <tr> <td>120 V AC/50 Hz</td> <td>3.5 amps operating;</td> <td>3.2 amps standby</td> </tr> <tr> <td>200 V AC/60 Hz</td> <td>2.0 amps operating;</td> <td>1.9 amps standby</td> </tr> <tr> <td>200 V AC/50 Hz</td> <td>2.0 amps operating;</td> <td>1.85 amps standby</td> </tr> <tr> <td>230 V AC/60 Hz</td> <td>1.8 amps operating;</td> <td>1.7 amps standby</td> </tr> <tr> <td>250 V AC/50 Hz</td> <td>1.75 amps operating;</td> <td>1.65 amps standby</td> </tr> </tbody> </table>	100 V AC/50 Hz	4.2 amps operating;	3.9 amps standby	100 V AC/60 Hz	4.1 amps operating;	3.85 amps standby	120 V AC/50 Hz	3.5 amps operating;	3.2 amps standby	200 V AC/60 Hz	2.0 amps operating;	1.9 amps standby	200 V AC/50 Hz	2.0 amps operating;	1.85 amps standby	230 V AC/60 Hz	1.8 amps operating;	1.7 amps standby	250 V AC/50 Hz	1.75 amps operating;	1.65 amps standby
100 V AC/50 Hz	4.2 amps operating;	3.9 amps standby																				
100 V AC/60 Hz	4.1 amps operating;	3.85 amps standby																				
120 V AC/50 Hz	3.5 amps operating;	3.2 amps standby																				
200 V AC/60 Hz	2.0 amps operating;	1.9 amps standby																				
200 V AC/50 Hz	2.0 amps operating;	1.85 amps standby																				
230 V AC/60 Hz	1.8 amps operating;	1.7 amps standby																				
250 V AC/50 Hz	1.75 amps operating;	1.65 amps standby																				

Appendix D: Using the Long Roll Accessory

The *Kodak Professional* HR 500 Film Scanner Long Roll Accessory lets you scan rolls of 35 mm-, 46 mm-, 70 mm-, and 120/220-size edited film.

For the highest quality scans:

- before scanning, to reduce the chance of artifacts, clean the film with Super Film Cleaner (see *Appendix B: Ordering Accessories and Supplies*) or an equivalent cleaner that has ionized air and particle transfer rollers (PTR)
- install and use the appropriate static elimination kit (see *Appendix B: Ordering Accessories and Supplies*)
- follow daily maintenance procedures to clean the rollers and the punch readers on the Long Roll Accessory
- calibrate the scanner for each new roll of film

CAUTION: Kodak recommends that you use one-inch film cores with the Long Roll Accessory. However, your lab may require that you use 3/4-inch film cores. It is critical that the fast forward and rewind speeds are correct for the size core you use. The fast forward and rewind speeds should never be greater than 10 inches per second.

<i>If you use</i>	<i>One-inch film cores</i>	<i>3/4-inch film cores</i>
	Maximum speed is 10 inches per second.	Maximum speed is 8 inches per second.
DP2 software	Consult your DP2 (<i>Kodak Professional</i> Digital Print Production Software) documentation.	
SAM software	See the instructions on page D-31.	

IMPORTANT: Before beginning the following installation procedure, check that the shipping box contains all items on the packing list. If it does not, contact your Kodak representative.

Installing the Software for the Long Roll Accessory

1. With the PC powered off, power on the scanner.
2. Wait for the series of 3 beeps to sound at the scanner (or for the lamp to illuminate).

You must have version 2.0 or higher of SAM (Service and Assembly Module) diagnostic software installed on the host computer and version 2.0 or higher of firmware on your scanner.

Downloading the Software and Firmware from KODAK.COM

1. Go to:
<http://www.kodak.com/global/en/service/software/hr500/navigation.shtml>
2. If the version numbers for either the SAM diagnostic software or firmware are higher than what is now installed on your scanner, follow the instructions on the Web site to download the newer versions of SAM and the HR 500 firmware.
3. Follow the installation instructions on the Web site.

Upgrading the Scanner's Firmware

NOTE: Check the Web site (see page D-2) for the most up-to-date instructions.

1. Open SAM and click the Transfer tab on the Operations window.

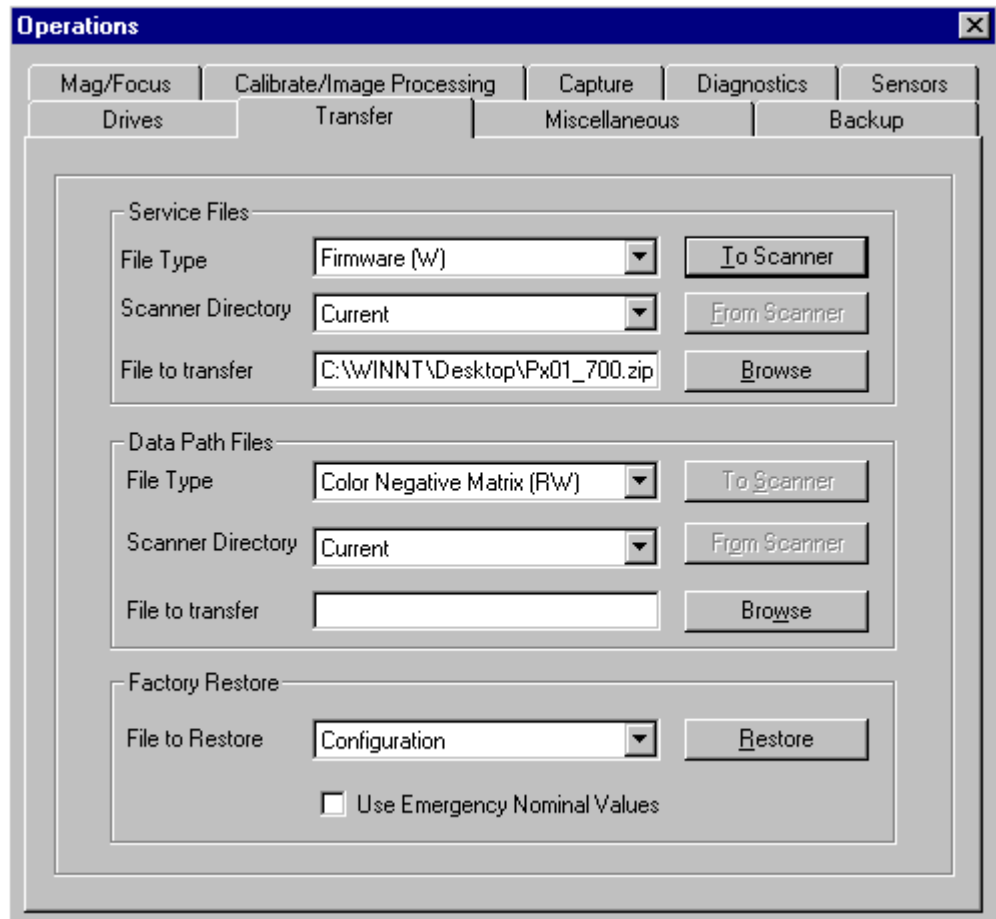

2. Make sure the **File Type** is Firmware (W).
3. Click **Browse** (in the **Service Files** area) and find the .zip file that you downloaded from KODAK.COM (example: HR500Px01_700.zip).
4. Click **Open**.
5. Make sure the Scanner Directory is set to **Current**.
6. Click **To Scanner** to start the transfer.
The transfer takes approximately one minute.

7. When the transfer is complete, select the Backup tab and click **Backup**.

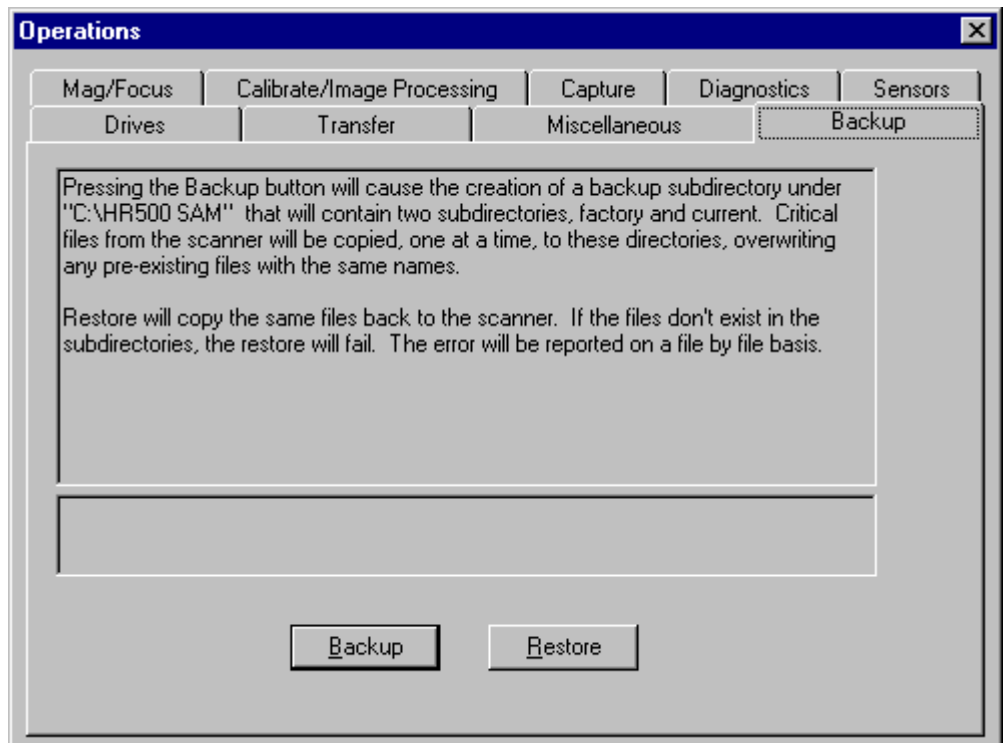

8. When the backup is complete, exit SAM.

Installing or Removing the Long Roll Accessory

IMPORTANT: Because of manufacturing tolerances, aperture plates and Long Roll Accessories cannot be interchanged.

If your lab has more than one Long Roll Accessory, you may want to use labels with the same colors or numbers to identify aperture plates with the associated Long Roll Accessory.

Overview of Parts

The parts shown below are shipped with the Long Roll Accessory. Although not shown, 5 aperture plates are also shipped with each Long Roll Accessory.

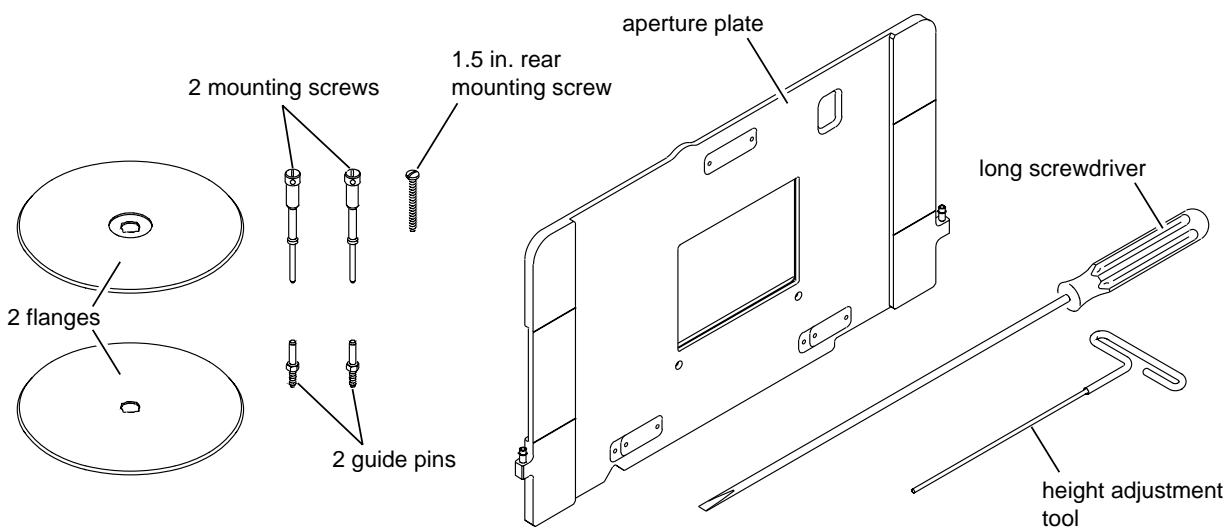

Preparing the Scanner for the Long Roll Accessory

You must remove the film holder guide from the scanner before you install the Long Roll Accessory.

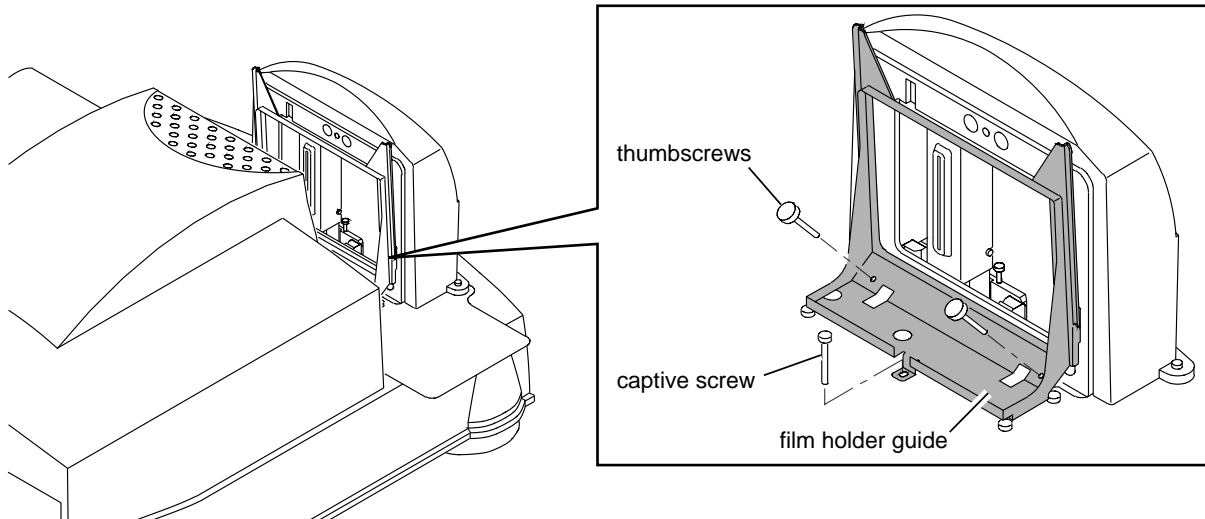

CAUTION: As indicated in Step 1 below, make sure the scanner is powered OFF.

1. Power off the scanner.
2. Remove the two thumbscrews and loosen the captive screw.
3. Lift the film holder guide up and off the scanner.

CAUTION: Use canned or pressurized air to remove any dust or debris from the connector.

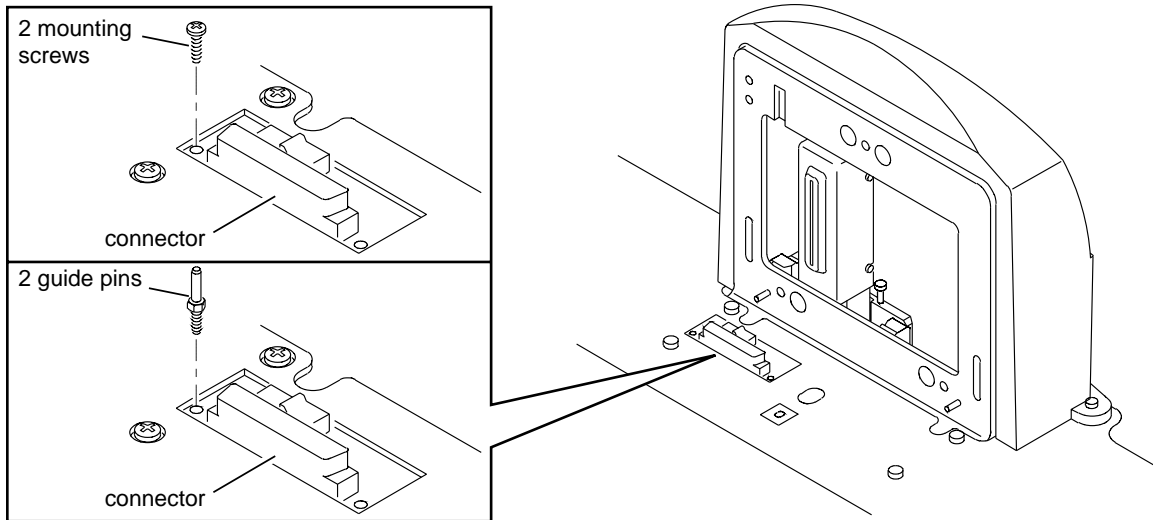

4. Inspect and remove any dust and debris from the connector.
5. Remove the two mounting screws on each side of the connector.
6. Insert the two guide pins in the holes from which you removed the mounting screws.
7. Tighten the guide pins with a 1/4-in. open-end wrench.

Attaching the Long Roll Accessory to the Scanner

CAUTION: Make sure the scanner is powered OFF.

1. Grasp the large rectangular opening to lift and remove the Long Roll Accessory from the shipping box.

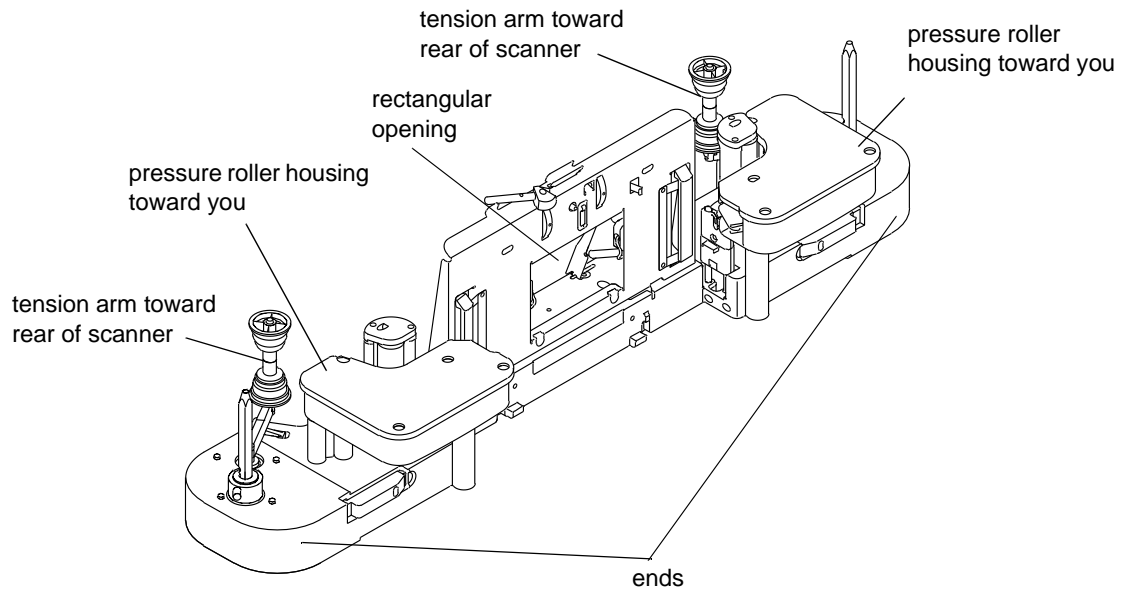

2. Hold the Long Roll Accessory at the ends and carry it to the scanner.
3. Position the Long Roll Accessory so the two pressure roller housings are toward you and the two tension arms are toward the rear of the scanner.

CAUTION: Avoid hitting the light bar and the safety switch on the scanner.

4. Center the alignment blocks on the Long Roll Accessory between the two dowel pins on the scanner.

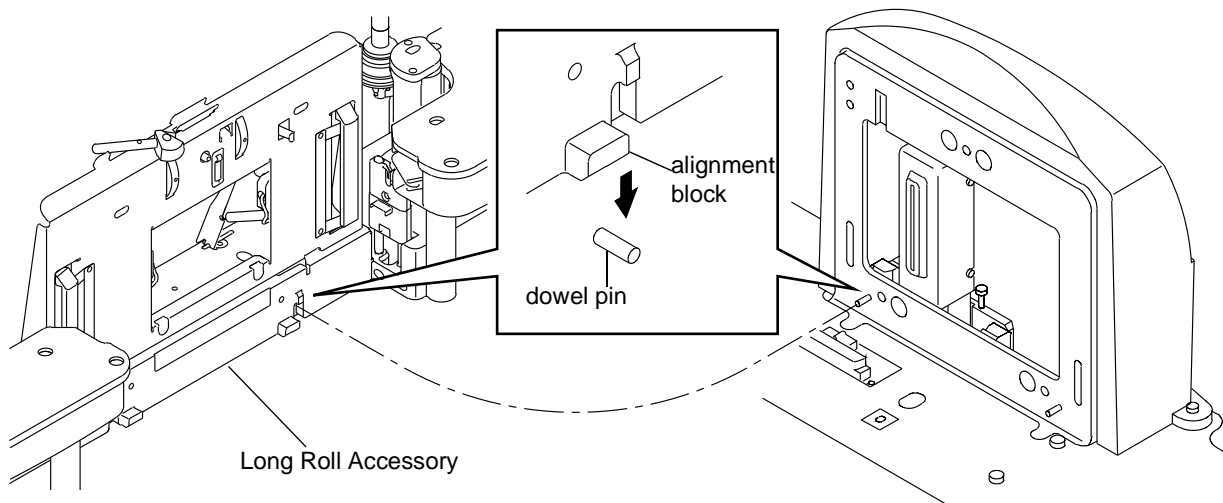

5. Gradually lower the Long Roll Accessory to rest in place on the scanner.

CAUTION: When installing the mounting screws in the next step, use care to avoid

- dropping the screws inside the scanner
- cross threading the screws

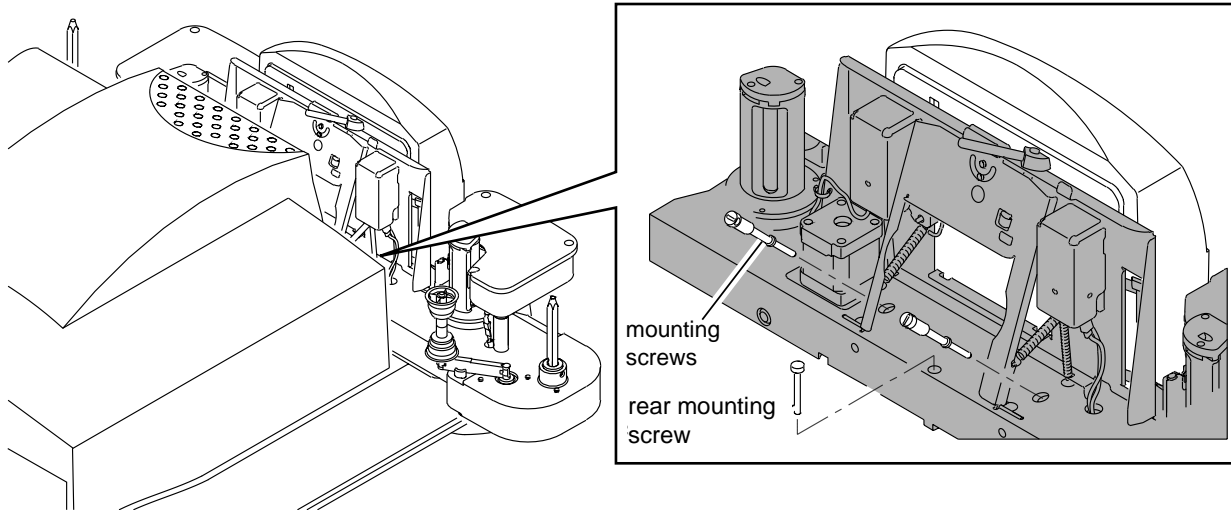

6. Install, but do not fully tighten, the rear mounting screw.
7. Hold each of the two mounting screws at the angle of the holes (approximately 45 degrees) and install, but do not tighten, the screws.

CAUTION: In the next step, do not overtighten the mounting screws.

8. Using the long screwdriver provided, tighten the 3 mounting screws until you feel resistance.

Latching and Unlatching the Gate Actuator

Be sure you know how to latch and unlatch the gate actuator before installing the aperture plate. The gate actuator must be in the unlatched position for film loading and in the latched position for scanning.

Latching the Gate Actuator

CAUTION: Be sure the gate actuator is latched before you move the locking arm to the locked position.

1. Pull the gate actuator toward you until the gate “latches” in place.
2. To lock the gate actuator, move the locking arm to the left (locked) position.

Unlatching the Gate Actuator

CAUTION: Always move the locking arm to the unlocked position before unlatching the gate.

To unlatch the gate actuator, manually squeeze the two tabs together and release.

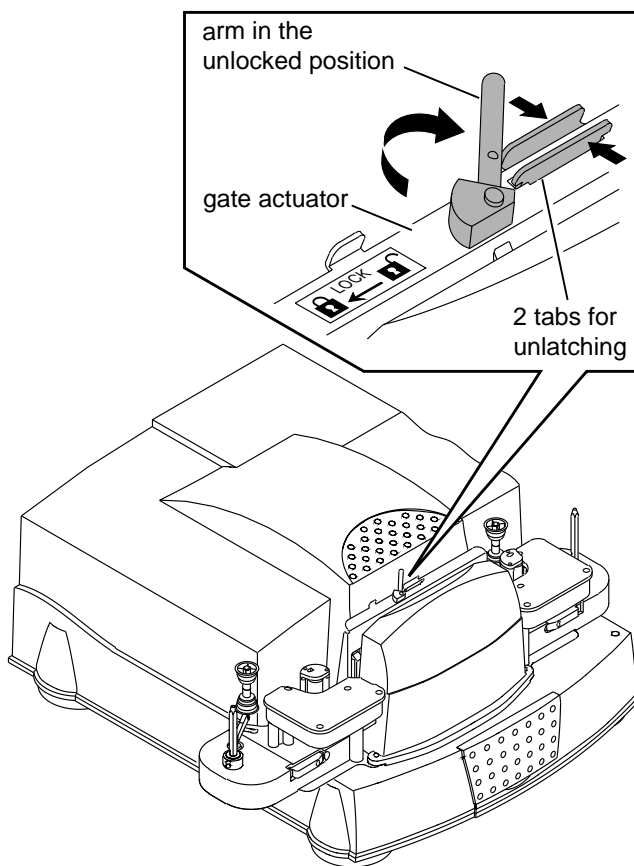

Installing the Aperture Plate

IMPORTANT: To power on the scanner without error, an aperture plate must be installed, latched, and locked.

1. Choose the aperture plate corresponding to the film format you will be scanning.

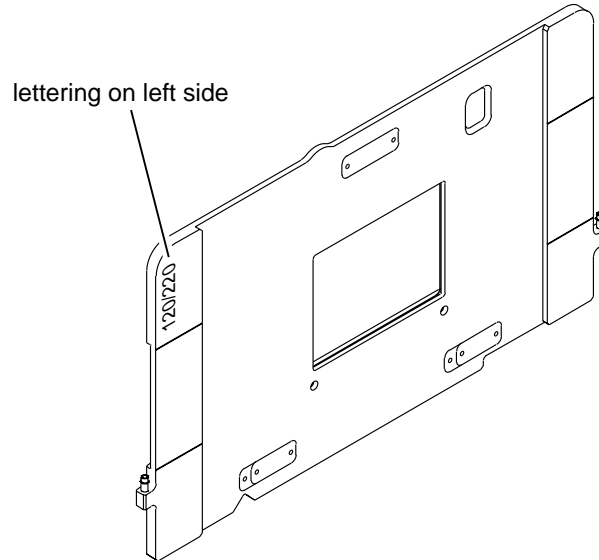

2. Position the aperture plate with the lettering (example: 120/220) visible on the left side.

CAUTION: Installing an aperture plate backwards may result in a damaged light bar.

3. Make sure the gate actuator is unlatched for film loading.

4. Center the aperture plate on the lamphouse cover.

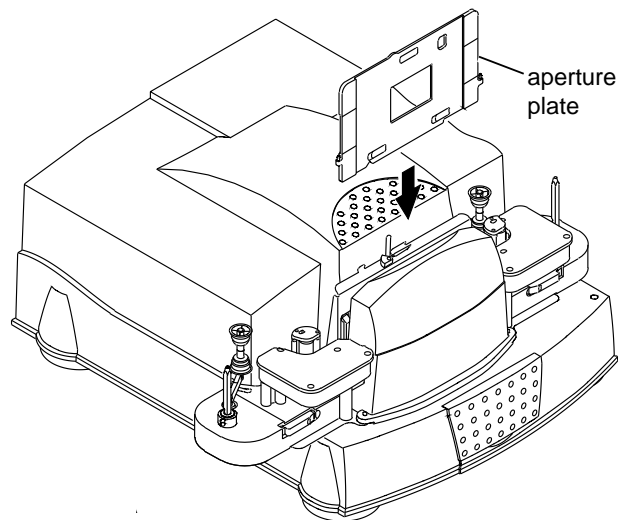

5. Gently lower the aperture plate and, when you feel resistance, push until it is secured.

Removing the Long Roll Accessory from the Scanner

It may be necessary to remove the Long Roll Accessory from the scanner.

CAUTION: Make sure the scanner is powered OFF.

To remove the Long Roll Accessory, reverse the installation procedure (see pages D-8 through D-12 for more details):

1. Remove the aperture plate from the Long Roll Accessory. See *Latching and Unlatching the Gate Actuator* on page D-11.
2. Power off the scanner.

CAUTION: When removing the mounting screws in the next step, use care to avoid dropping the screws inside the scanner.

3. Loosen and remove the 3 mounting screws.

CAUTION: Avoid hitting the light bar and the safety switch.

4. Remove and lift the Long Roll Accessory from the scanner.
5. Place the Long Roll Accessory on a flat surface.

Punch Sensors

The punch (data hole) sensors are set up at the factory for negative-type film and require no adjustment during the installation procedure. If you will be scanning film that has a significantly higher or lower D-min from negative film, such as black-and-white film or color positive film, see *Determining and Setting the Trigger Points* on page D-34.

Setting the Punch Reader Height for the Current Film Size

Because of differences in film editors, there is no standard punch reader height. You must set the height of the left and right punch readers, one at a time, to accommodate your editor.

For each film size that you use:

- Install the appropriate aperture plate.
- Adjust the core locator height on the spindle.
- Thread the film.
- Set the punch reader height (this is a one-time adjustment that can be done during installation or when the aperture plate is used for the first time).

The aperture plate should already be installed. If not, install it (see *Installing the Aperture Plate* on page D-12).

Adjusting the Core Locator Height on the Spindle

The spindles on the Long Roll Accessory have core locators to accommodate different film sizes.

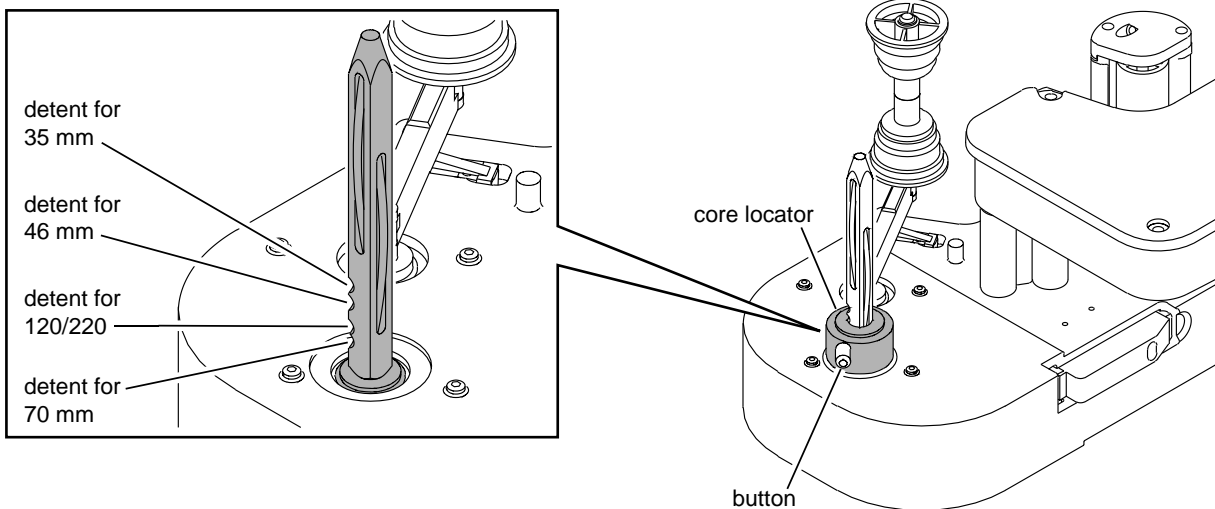

Push and hold the button to release and position the core locator at the correct detent. Release the button at the detent you want. The detent positions are:

- 35 mm (top)
- 46 mm
- 120/220 (62 mm)
- 70 mm (bottom; closest to Long Roll Accessory)

Loading and Threading Film

IMPORTANT: Careful handling of film is extremely important. Before loading film, clean the film with Super Film Cleaner or an equivalent cleaner that has ionized air and particle transfer rollers (PTR).

Use canned air to clean the punch readers before threading film.

Before loading film, make sure you have at least 2 feet (.6 meters) of leader at each end of the roll.

CAUTION: In the steps below, be sure you determine and use the correct orientation of the flange. Incorrect setup will result in film tracking problems and loose takeups.

1. Determine the orientation of the flange for the reel or core you selected for loading:

- A flange in the upright position is for thin reels
- A flipped flange is for film on cores
- No flanges are needed for thick reels

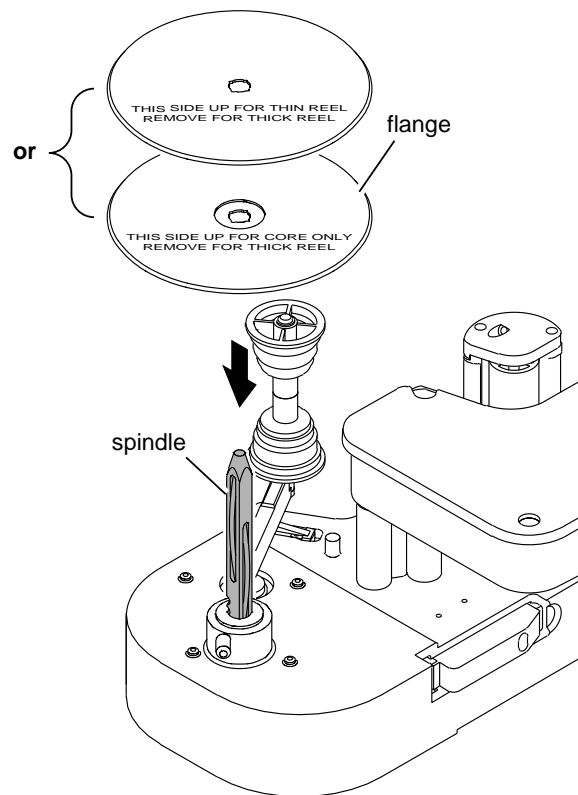

2. If you are using either thin reels or core only, install the flanges on the spindles with the appropriate side up.

Threading the Film

1. Position the film with the data holes down and the emulsion toward the imager.

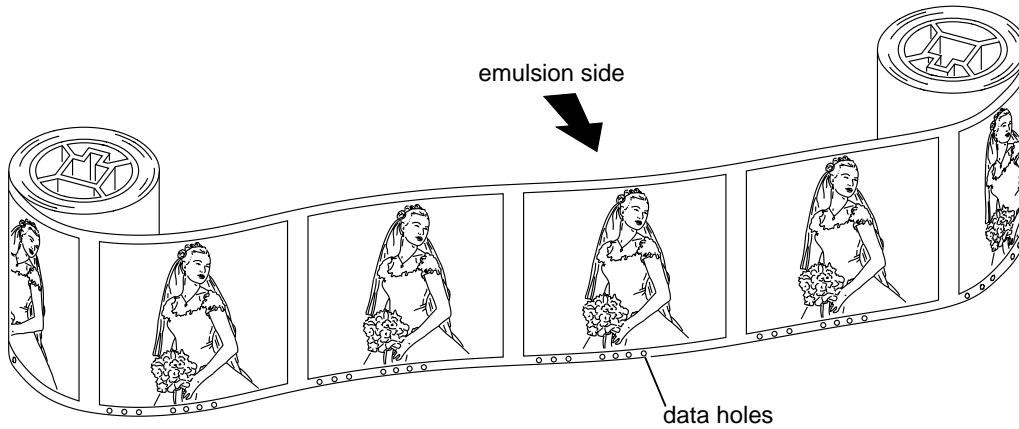

NOTE: You can thread the film from either side of the Long Roll Accessory.

2. Install the film on the spindle.

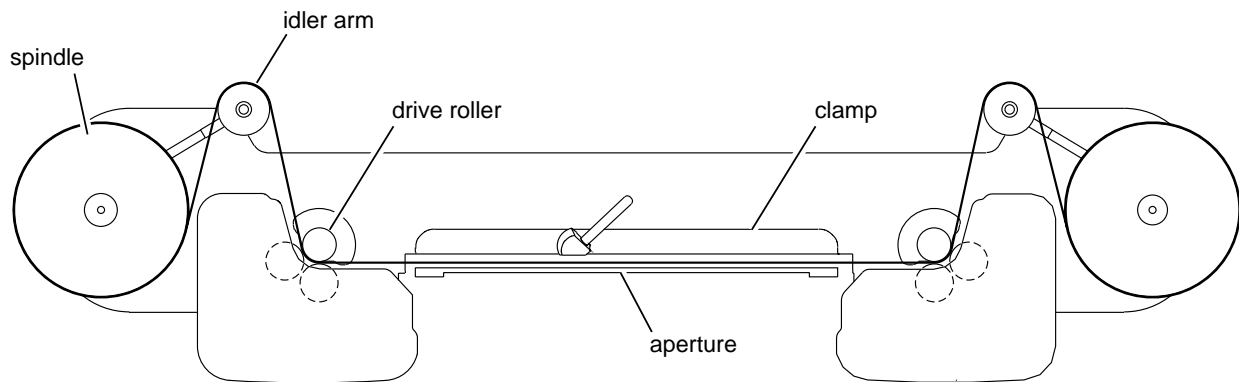

3. Thread the film:

- a. around the idler arm
- b. around the drive roller
- c. between the aperture and the clamp, keeping the film in the track (grasp the film on either side to locate the film in the track)
- d. around the drive roller and idler arm

4. After the film is threaded, pull the gate actuator forward to latch it against the aperture plate. Move the locking arm to the left (locked position).

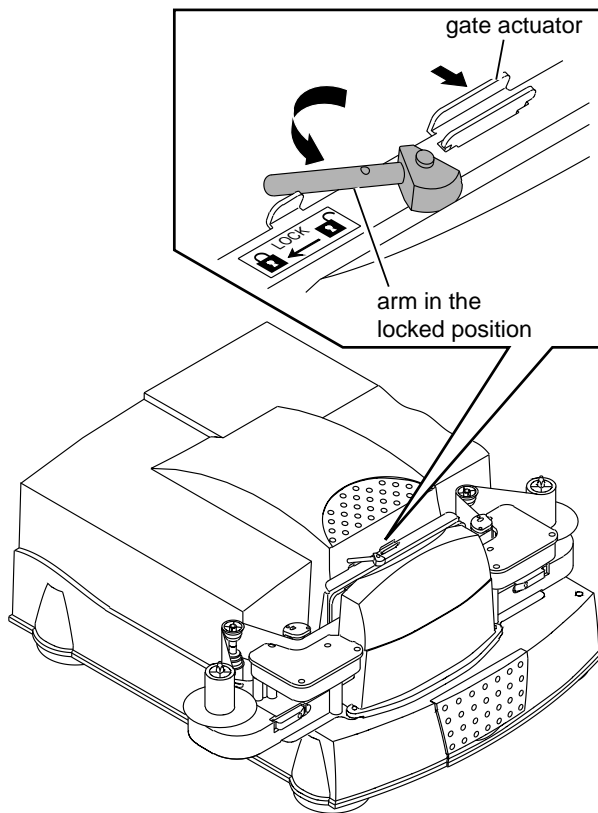

Setting the Punch Reader Height

1. Open SAM.
2. Click the LAMP button to turn the lamp off. When the lamp is off, it is easier to work in the area of the punch reader.



toggles to turn the lamp off and on

3. Select *View>Film Controls*.



4. Click **Load Film**.

A dialog box appears.

5. Click **OK**.

6. In preparation for the reader height adjustment, click **Fast Fwrd>>** to advance the film approximately 10 feet, then click **<<Rewind** to reverse the film the same distance.

NOTE: Advancing and rewinding the film ensures that the film is correctly positioned in the film track relative to the readers.

Installing the Adjustment Tool

1. Locate the left and right adjusting screws on either side of the aperture plate.
2. Install the height adjustment tool in the right or left adjusting screw.

NOTE: You will install the adjusting tool in each adjusting screw; whether it is the left or right screw is determined by which punch reader you adjust first.

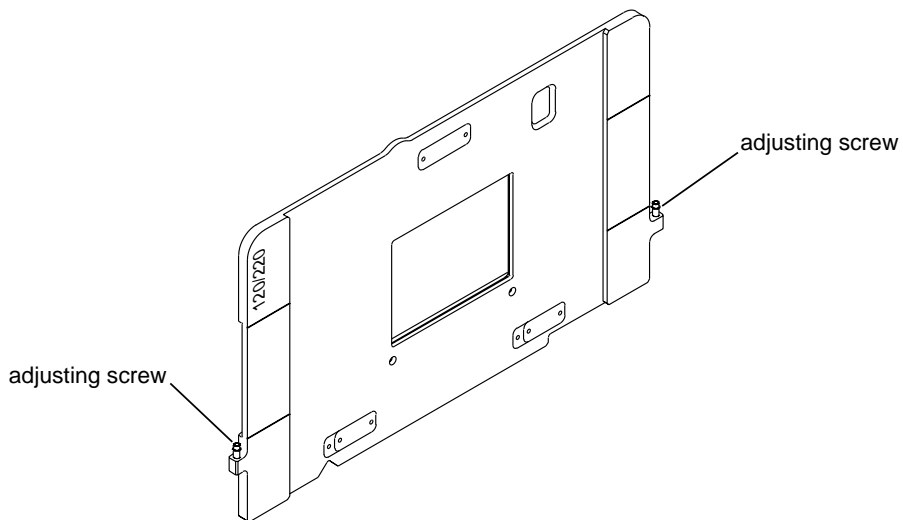
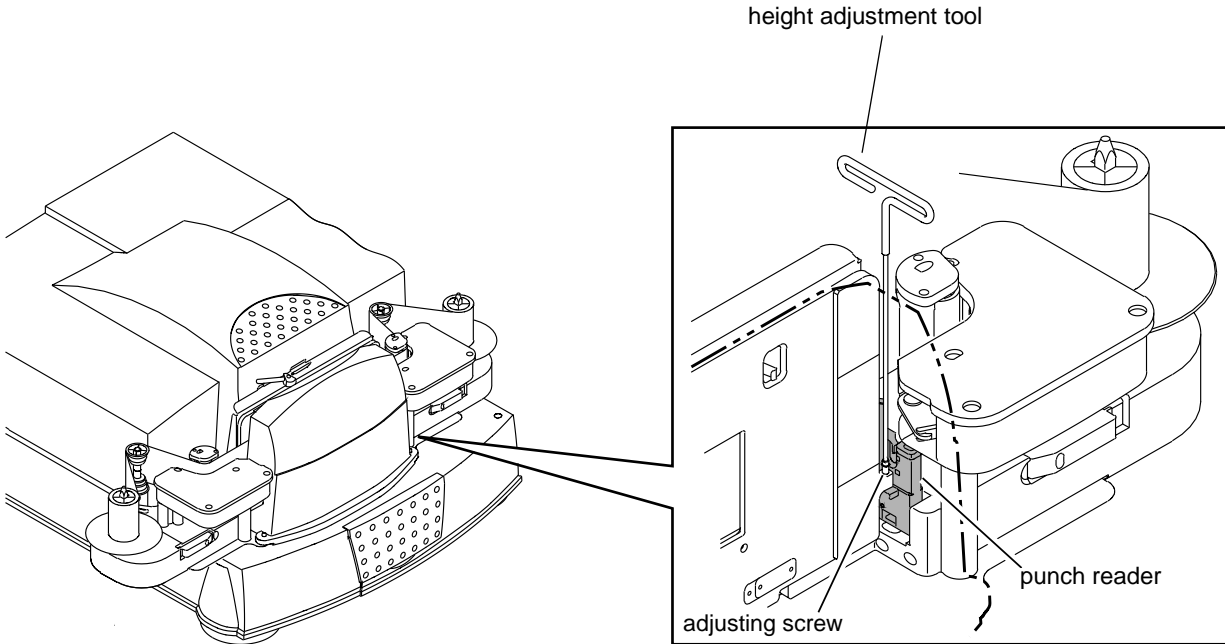

Visually Checking the Punch Reader Height

1. Look at the small blue light located in the notch at the top of the punch reader, which is below the pressure rollers and adjacent to the edge of the aperture. The blue light should be in line with the punches in the film.
2. Align the light to the data holes by turning the adjusting screw clockwise to lower the light or counterclockwise to raise the light.

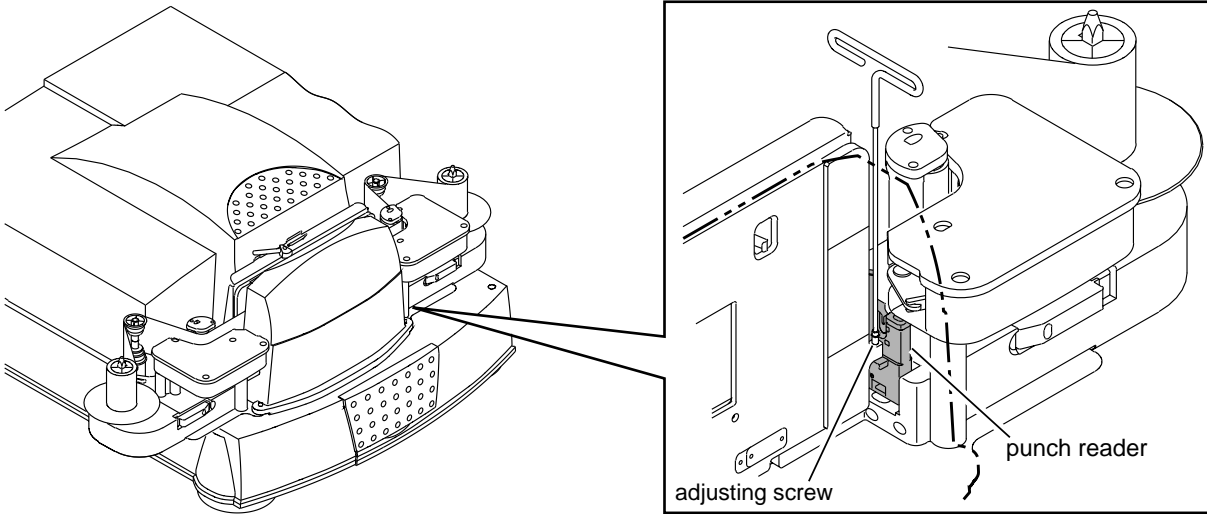

Adjusting the Punch Reader Height

Adjust both the left and right reader heights such that the punch reader fully distinguishes between a data hole and film.

No specific numbers represent data holes or film, but lower numbers indicate the presence of film and higher numbers indicate the presence of data holes. (See *Recording the Highest Numbers on the LEDs* on page D-34 for the location of the LED numbers.)

For both the left and right readers:

1. On the Film Controls window, click **Position >** several times to advance the film. As you advance the film, the reader should sense both holes and film.
If you do not see a significantly higher number after you see data holes, repeat *Visually Checking the Punch Reader Height* on page D-22
2. When you see a significantly higher number, stop advancing the film. Turn the adjusting screw until the number is maximized.
For example, as you click **Position >**, you may see a value of 580, but when you stop advancing the film and turn the adjusting screw, you may see a value of 620. This indicates a more effective reader height.
3. Repeat steps 1 and 2 to advance the film to another position and confirm your adjustment.
4. From SAM, turn the lamp on.

When the above procedures have been completed, you can begin scanning. Use your *Kodak Professional* Digital Print Production Software (DP2) (help is included) to produce quality scans.

IMPORTANT: *Remember to recalibrate the scanner for each roll of film. Use a camel's hair brush and canned air to remove dirt or dust from the light bar.*

Appendix D-1: Calibrating the Sensor Offsets

IMPORTANT: Do this procedure only if you will be using SAM to operate the scanner.

Do this procedure twice, once for the left sensor and once for the right sensor. For best visibility, use the largest film format you have.

NOTE: It is not necessary to prepare and load the film twice.

Preparing and Loading the Film

1. Create a roll of film with the center of several frames clearly marked.

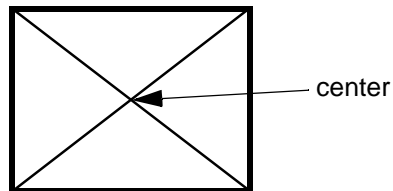

2. Edit the roll of film, making sure to center the mark in the crop box on the editor.
3. Load the edited film, beginning at the *left* side of the scanner (see *Loading and Threading Film* on page D-16).

4. In SAM, select *View>Film Controls*.



5. Click **Load Film**.

6. When the dialog box appears, click **OK**.

Setting the Lens Magnification

1. If the Operations window is not visible in SAM, select *View>Operations Controls*.

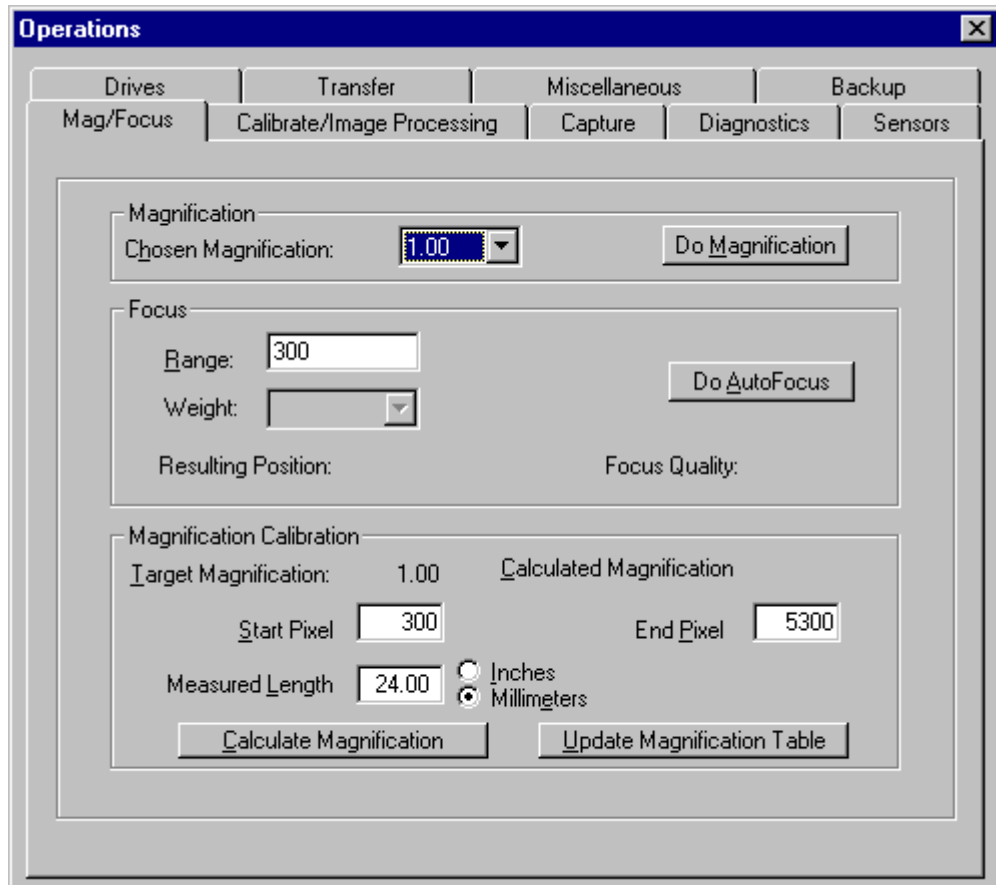

2. Select **1.00** as the **Chosen Magnification**.
3. Click **Do Magnification**.
4. Close the Operations window.

Setting the Scan Parameters

1. Select *Test>Long Roll Capture* from the SAM menu.

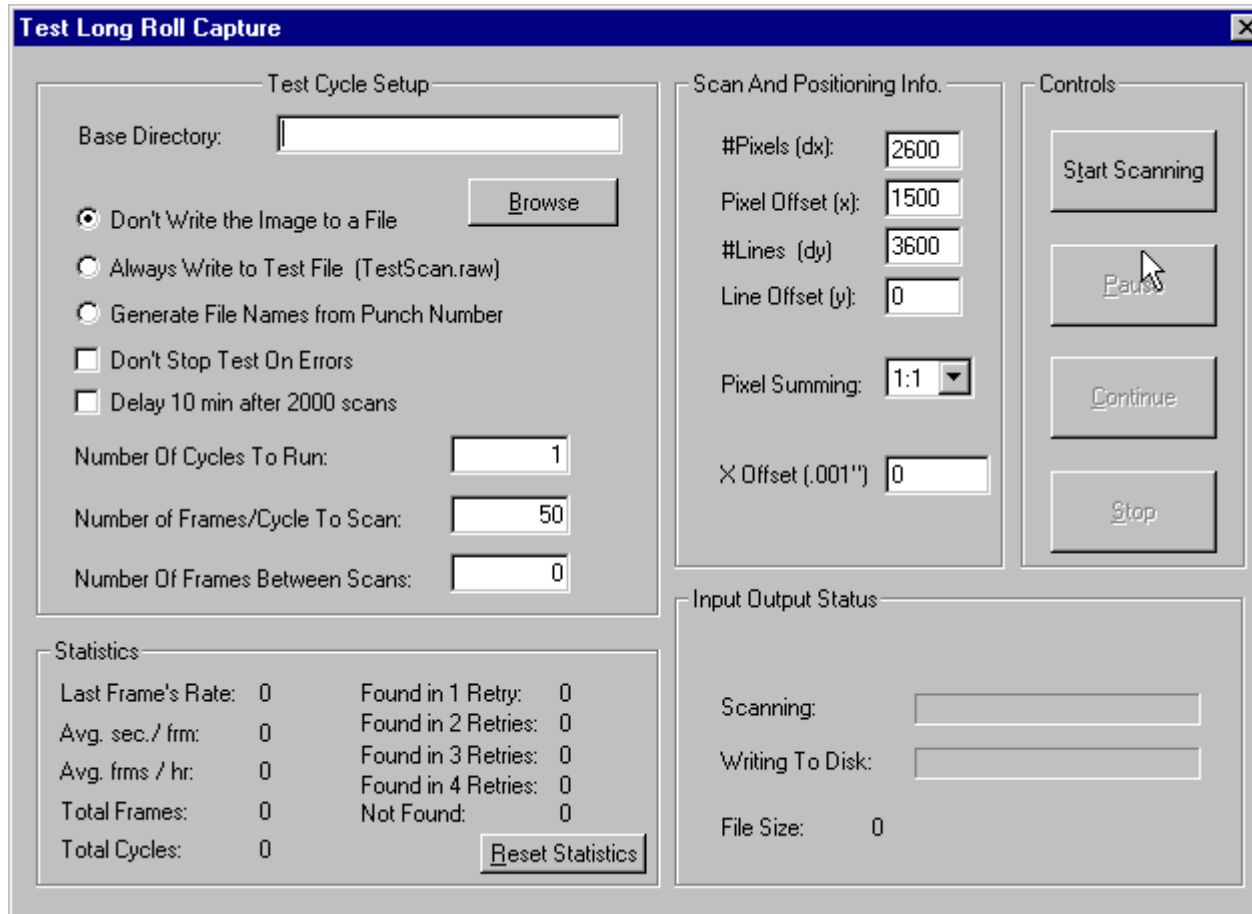

2. Set the Scan and Positioning Info.

- a. Set the **#Lines (dy)** to 1.
- b. Set the **Line Offset (y)** to 0.
- c. Set **Pixel Summing** to 1:1.
- d. Keep the default values for #Pixels (dx), Pixel Offset (x) and X Offset.

IMPORTANT: Make sure you close the Test Long Roll Capture window in the next step.

3. Close the Test Long Roll Capture window.

Locating the First Punched Frame

1. On the Film Controls dialog box, click **Load First Frm.** A dialog box appears.

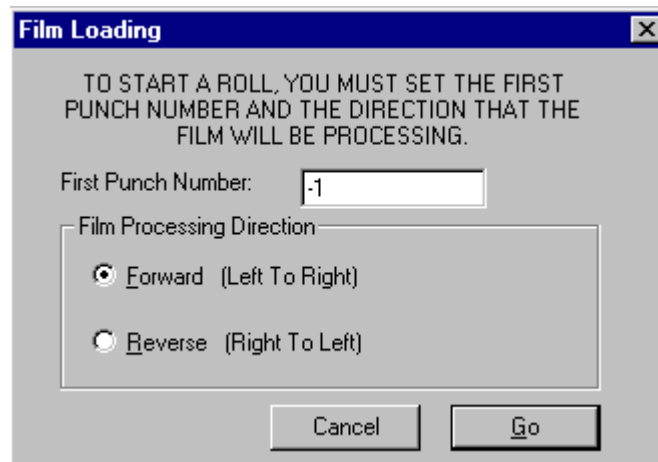

2. Select the Film Processing Direction:
 - If you are calibrating the left sensor offset, select **Forward (Left to Right)**.
 - If you are calibrating the right sensor offset, select **Reverse (Right to Left)**.
3. Type **-1** in the **First Punch Number** field.
-1 tells the scanner software to find the first punch (in the specified direction).
4. Click **Go**.

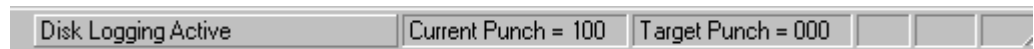

The status bar shows the Current Punch (the first punch found). The example shows that the first punch found is 100.

5. On the Film Controls dialog box, click **Seek Frame**.



A dialog box appears.

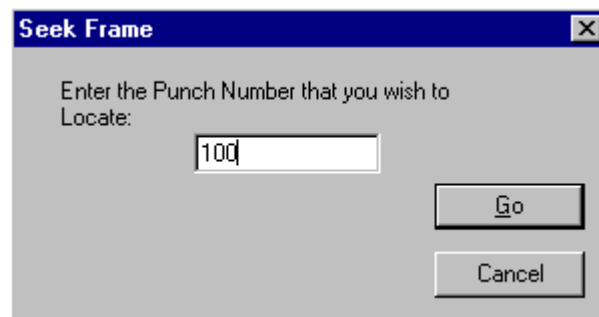

6. Type the **Punch Number** from the Current Punch on the status bar.

7. Click **Go**.

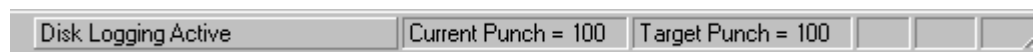

The Target Punch should equal the Current Punch.

Checking the Alignment and Adjusting the Sensor Offsets

- Using a flashlight, look from the rear of the aperture to check the alignment of the marked frame with the aperture plate.

The center of the frame should line up exactly with the right edge (from the front of the scanner) of the aperture plate.

NOTE: The area beyond the aperture plate is not visible when you are checking the alignment.

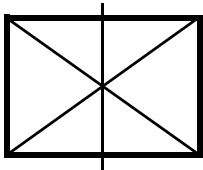
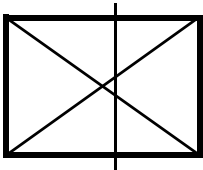
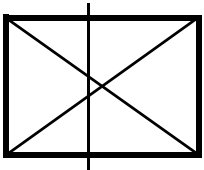
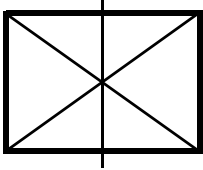
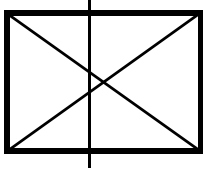
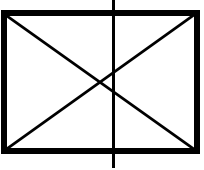
	Center of the frame lines up exactly with the right edge of the aperture plate	Center of the frame is beyond the edge of the aperture plate	Center of the frame has not reached the edge of the aperture plate
Film is moving left to right			
Film is moving right to left			

- In SAM, select *View>Configurations*.

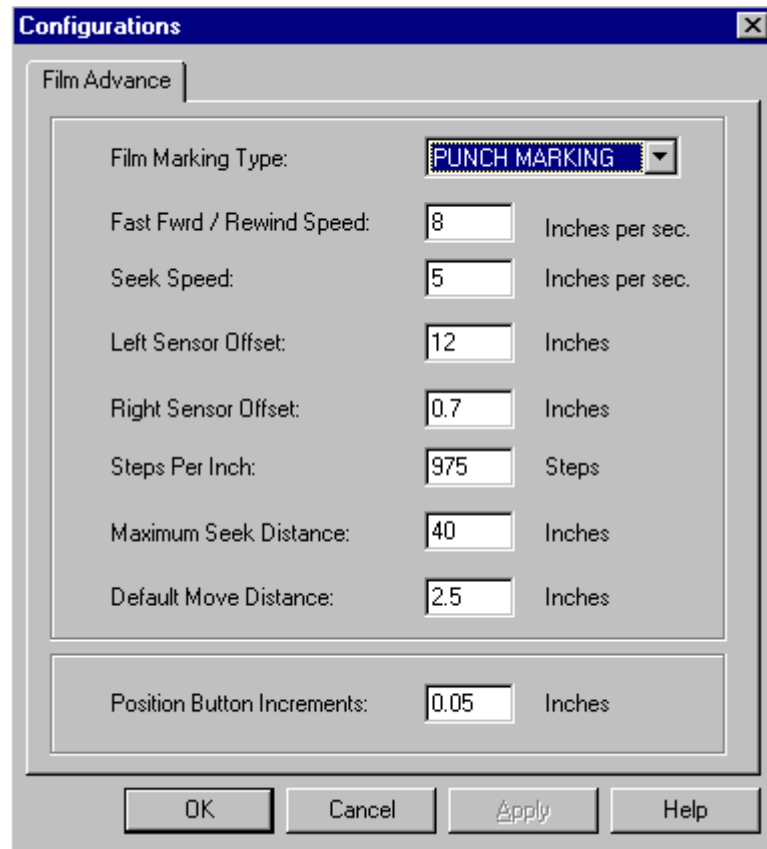

CAUTION: Fast Fwrd / Rewind Speed should never be greater than 10. If needed, change the speed to be 10 Inches per sec. or less.

As a guideline, the speed should be 10 inches per second if you use 1-inch film cores (the recommended size). The speed should be 8 inches per second if you must use 3/4-inch cores.

- Make sure the correct **Film Marking Type** is selected and that the **Left** and **Right Sensor Offsets** are correct for the film and the editor you are using.
 - For Offset Punch Editors, set the **Left Sensor Offset** to 12 and the **Right Sensor Offset** to 0.7.
 - For Center Punch Editors, set the **Left Sensor Offset** to 7.75 and the **Right Sensor Offset** to 4.95.
- Set **Position Button Increments** to 0.05 inches.
This number determines the distance film is moved when you click the **Position>** button on the Film Controls window when setting the reader height.
- Click **OK**.

6. If the marked frame is not aligned with the right edge of the aperture plate, select *View>Configurations*.

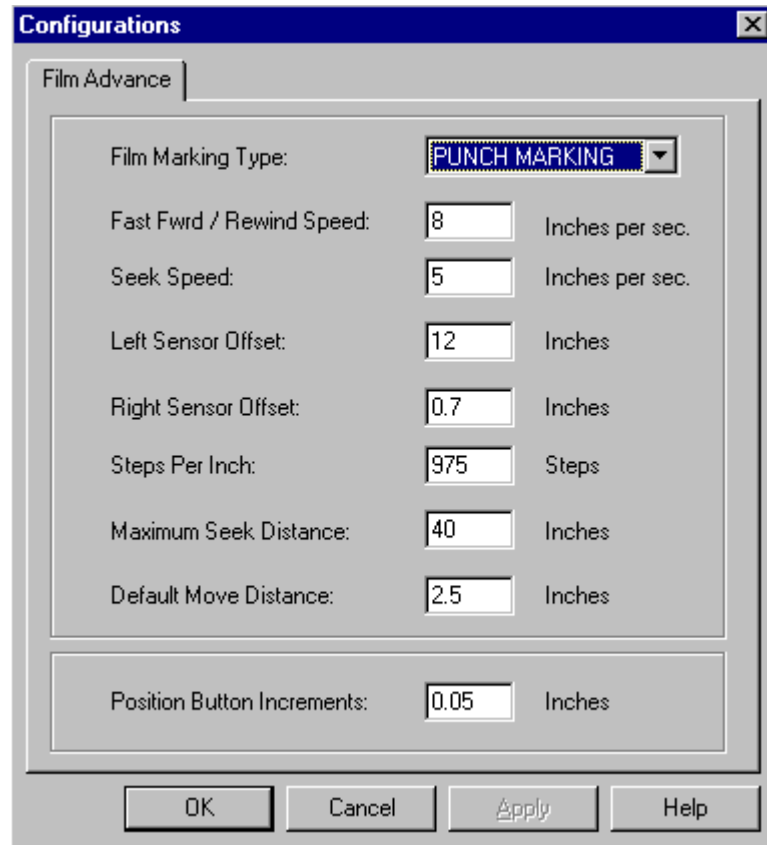

- a. If the film is moving from left to right, change the **Left Sensor Offset**:
If the center of the frame is beyond the right edge of the aperture plate, decrease the **Left Sensor Offset**.
If the center of the frame has not reached the right edge of the aperture plate, increase the **Left Sensor Offset**.
- b. If the film is moving from right to left, change the **Right Sensor Offset**:
If the center of the frame is beyond the left edge of the aperture plate, decrease the **Right Sensor Offset**.
If the center of the frame has not reached the left edge of the aperture plate, increase the **Right Sensor Offset**.

7. On the View Controls window, click **Next Frame**.
8. Repeat steps 1 through 7 until the center of the frame lines up exactly with the right edge of the aperture plate.
9. On the View Controls window, click **Fast Fwrd>>** to advance the roll of film to the right side.
10. Repeat *Locating the First Punched Frame* (see page D-28) and *Checking the Alignment and Adjusting the Sensor Offsets* (see page D-30) for the right sensor.

Appendix D-2: Determining and Setting the Trigger Points

IMPORTANT: Do this procedure only if you will be scanning film that has a significantly higher or lower D-min from negative film, such as black-and-white film or color positive film.

1. With the PC powered off, power on the scanner.
2. Wait for the series of 3 beeps to sound at the scanner (or for the lamp to illuminate).
3. Power on the PC.

Recording the Highest Numbers on the LEDs

IMPORTANT: There must not be film in the scanner.

1. Open the plastic cover.
2. Look at the red LED number on the right side of the Long Roll Accessory. Note this number as being the "highest" number on the right side.

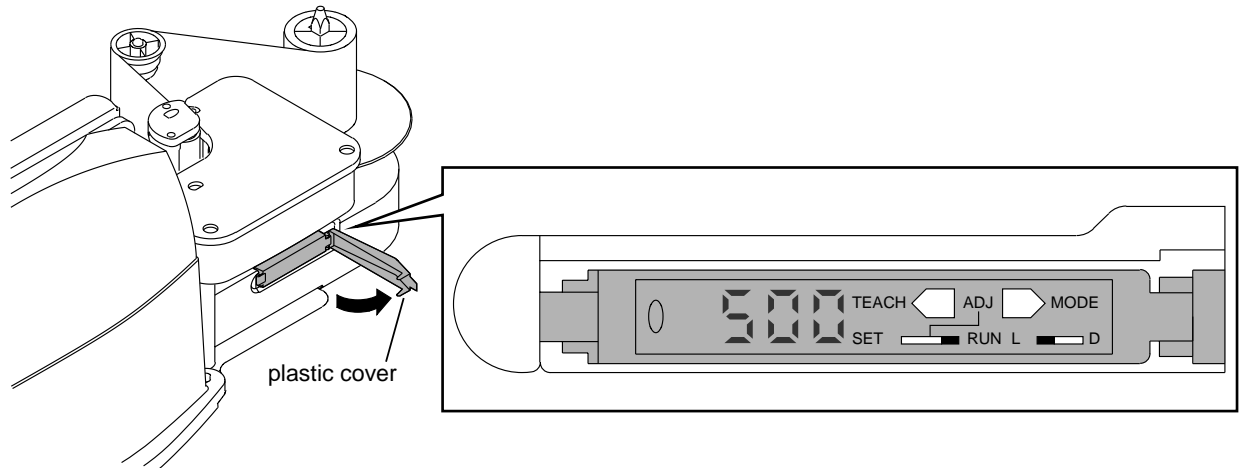

3. Look at the red LED number on the left side. Note this number as being the "highest" number on the left side.

4. Record the left and right highest numbers for later calculating the trigger numbers.

Because the readers are separate, the left and right numbers will not be the same.

The trigger number tells the scanner when it senses a change in light level. You need to set the trigger number only once unless you will be using the scanner for multiple types of film, such as for both negative and positive.

Determining the Left Trigger Point

1. On the Film Controls window of SAM, click **Position >** to advance the film and determine the “average” low number (indicating the presence of film) on the left LED.

An example is **120**.

2. Subtract the average low number from the highest number you recorded in step 3 under *Recording the Highest Numbers on the LEDs*.

An example of the highest number is **800**. Subtracting 120 from 800 results in **680**.

3. Divide the result of step 2 by 4.

Continuing the example, **680** divided by **4** equals **170**.

4. Add the result of step 3 to the average low number determined in step 1.

The result is the left trigger point. Record this number.

Continuing the example, **170** added to **120** equals **290**; 290 would be the left trigger point.

Determining the Right Trigger Point

1. On the Film Controls window, click **Position >** to advance the film and determine the “average” low number on the right LED.
2. Subtract the average low number from the highest number you recorded in step 1 under *Recording the Highest Numbers on the LEDs*.
3. Divide the result of step 2 by 4.
4. Add the result of step 3 to the average low number determined in step 1.

The result is the right trigger point. Record this number.

Below are examples of determining trigger points. Round to the nearest whole number.

<i>Average Low Number</i>	<i>Starting High Number</i>	<i>Difference Between High Number and Low Number</i>	<i>Difference Divided by 4</i>	<i>Trigger Number</i>
120	800	$800 - 120 = 680$	$680/4 = 170$	$170 + 120 = 290$
98	814	$814 - 98 = 716$	$716/4 = 179$	$179 + 98 = 277$

Setting the Trigger Points at the Scanner

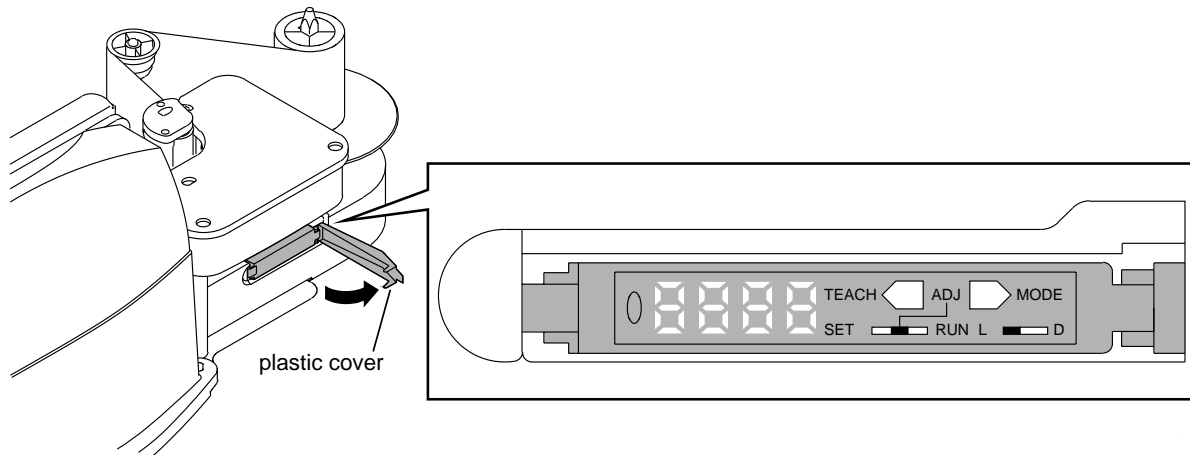

1. On the left side of the scanner:
 - a. Move SET/ADJ/RUN to **ADJ**.
 - b. Press **MODE** to increment the number (or press **TEACH** to decrement the number) to the value you determined to be the left trigger point.
 - c. Move SET/ADJ/RUN to **RUN**.
2. On the right side of the scanner:
 - a. Move SET/ADJ/RUN to **ADJ**.
 - b. Press **MODE** to increment the number (or press **TEACH** to decrement the number) to the value you determined to be the right trigger point.
 - c. Move SET/ADJ/RUN to **RUN**.
3. Close the plastic cover.

Appendix D-3: Maintenance

Perform these maintenance procedures at least once a day.

1. In SAM, select *View>Film Controls*.



2. Click **Tension Off** and remove film from the gate.

NOTE: It is not necessary to completely unthread the film.

Cleaning the Punch Readers

1. Locate the two punch readers, below the pressure rollers and adjacent to the left and right edges of the aperture.

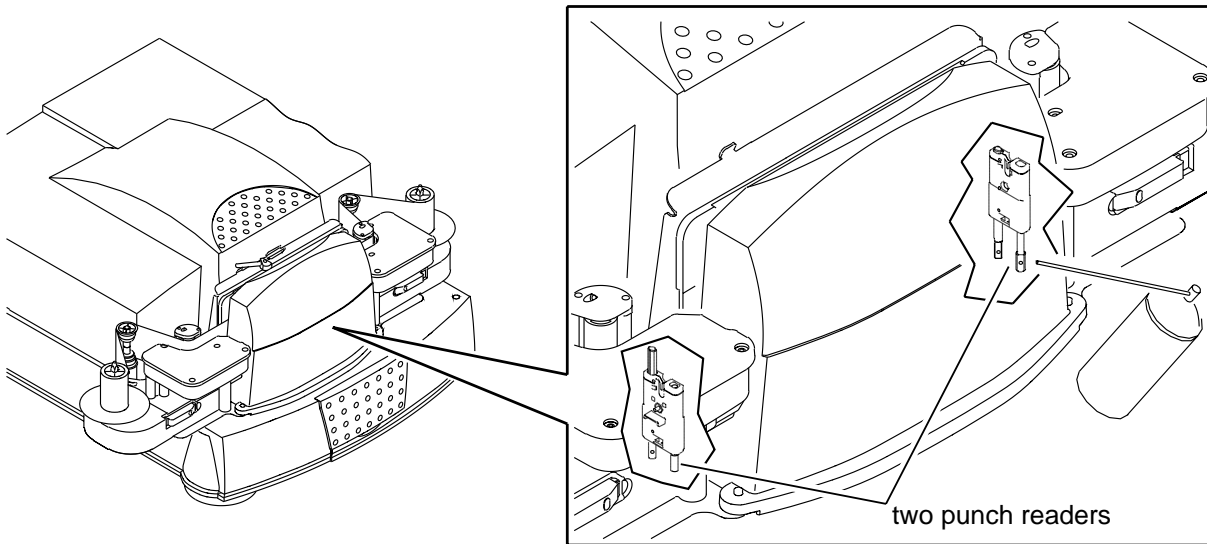

2. Use canned air to clean the left and right punch readers.

Cleaning the Rollers

1. In SAM, select *View>Film Controls*.



2. On the Film Controls window, click **Clean Rollers**.

A dialog box appears.



3. Make sure no film is in the gate. Click **Yes**.

The rollers rotate.

CAUTION: In the step below, do not use rubbing alcohol.

4. Using a lint-free cloth with 90% or higher isopropyl alcohol, wipe the exposed part of the moving rollers—in the slot at the rear of the housing—from top to bottom. Repeat until the cloth stays clean.

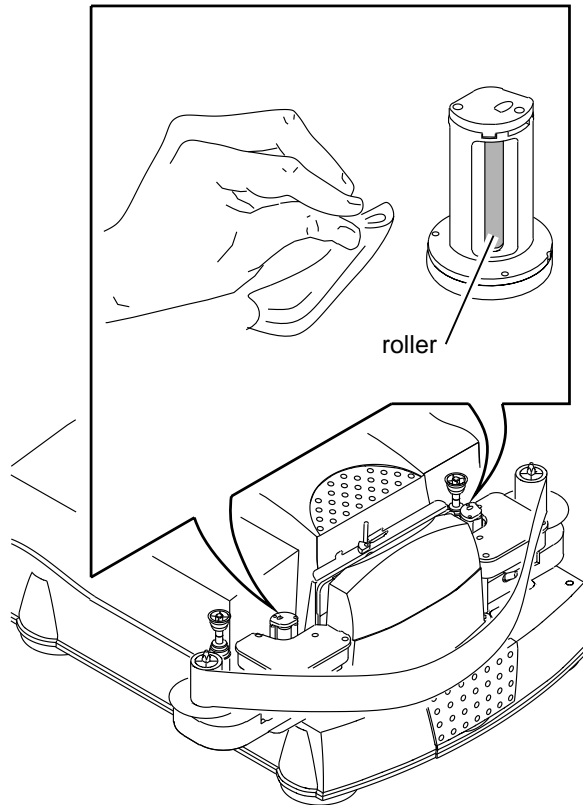

5. On the Film Controls window, click **Stop**.

Appendix D-4: Initial Setup of Sensors

IMPORTANT: Do this procedure only if you installed a new sensor or if the sensor setup was accidentally changed.

Resetting the Sensors to the Factory Values

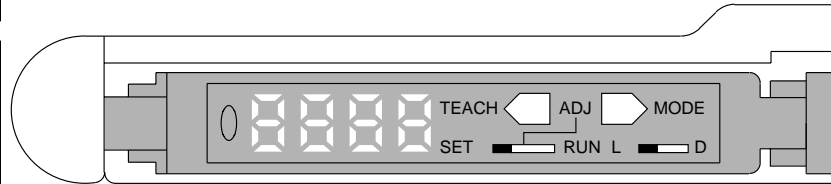
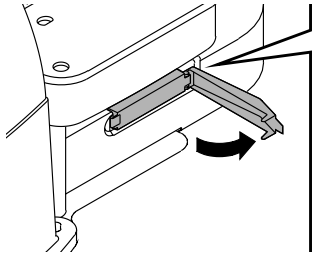

1. Move SET/ADJ/RUN to **SET**.
2. Simultaneously, press and hold **TEACH** and **MODE** until **nO ?** appears (about 5 seconds).

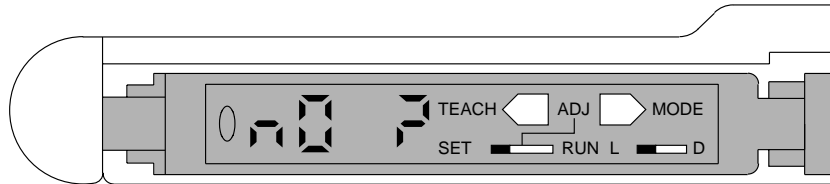

NOTE: To cancel resetting the sensors to the factory values, press **MODE**.

3. Press **TEACH** until **yES?** appears.

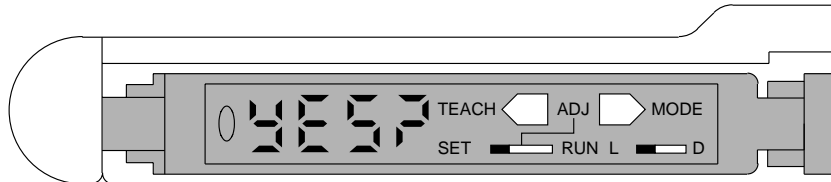

4. Press **MODE**.
5. Move SET/ADJ/RUN to **RUN**.

Programming the Sensors for the Long Roll Accessory

Power on the scanner.

NOTE: The display on the left sensor will be inverted.

Programming the Left Sensor

1. Open the plastic cover on the left display.
2. Make sure the operation mode selector is set to **L**.

NOTE: L means that light triggers high numbers. D means that dark triggers high numbers.

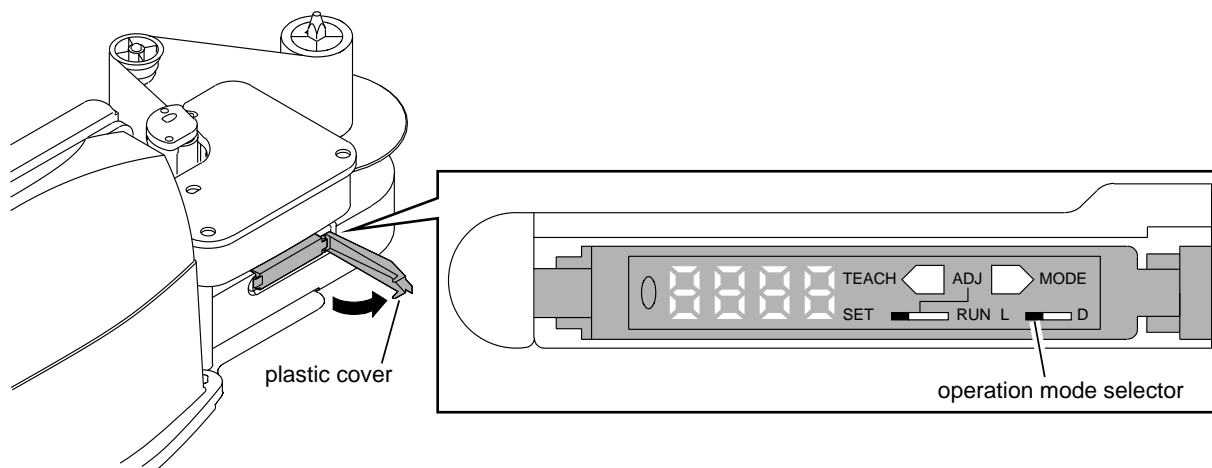

3. Move SET/ADJ/RUN to **SET**.
4. Press and hold **MODE** until **d123** appears (123 is inverted).

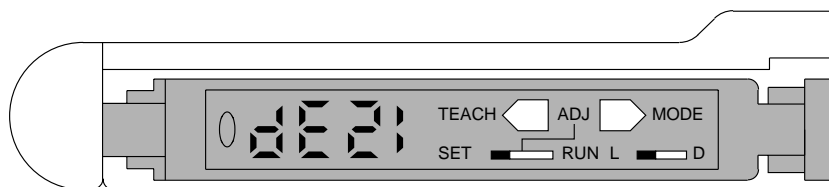

5. Press **TEACH**.
6. Change the Detection Function Setting to **F HS** (high speed):
 - a. Press and hold **MODE** until **F St** appears.

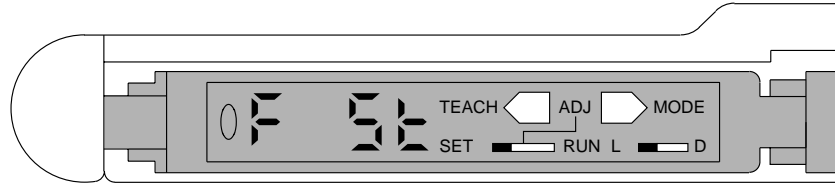

- b. Press **TEACH** once. **F Ld** appears.
- c. Press **TEACH** again. **F HS** appears.
- d. Move SET/ADJ/RUN to **RUN**.

Programming the Right Sensor

1. Open the plastic cover on the right display.
2. Make sure the operation mode selector is set to **L**.
3. Move SET/ADJ/RUN to **SET**.
4. Change the Detection Function Setting to **F HS**:
 - a. Press and hold **MODE** until **F St** appears.
 - b. Press **TEACH** once. **F Ld** appears.
 - c. Press **TEACH** again. **F HS** appears.
 - d. Move SET/ADJ/RUN to **RUN**.

Appendix D-5: Table of Scan Area Values

NOTE: Use the table below only as a starting point for determining scan area values.

Long-Roll Film Holders	Magnification	# Pixels	Pixel Offset	# Lines	File Size (MB)
35 mm double- perforated	.50	1020	2490	1538	4.5
	1.03	2102	1949	3168	19.1
	2.00	4081	960	6151	71.8
35 mm unperforated	.50	1259	2371	1741	6.3
	1.03	2594	1703	3586	26.6
	2.00	5038	481	6964	100.4
46 mm	.50	1752	2124	2381	11.9
	.60	2102	1949	2858	17.2
	1.58	5535	233	7525	119.2
6 x 4.5 cm vertical	.50	2378	1811	1539	10.5
	.66	2616	1431	2031	18.2
	1.26	5993	4	3878	66.5
6 x 6 cm	.50	2378	1811	2250	15.3
	.55	2616	1692	2475	18.5
	1.26	5993	4	5670	97.2
6 x 7 cm	.50	2378	1811	2775	18.9
	1.26	5993	4	6994	119.9
6 x 9 cm	.50	2378	1811	3495	23.8
	1.16	5517	242	8108	128.0
Split 70 mm	.50	2720	1640	1632	12.7
	.63	3427	1287	2056	20.2
	1.10	5984	8	3591	61.5
70 mm	.50	2720	1640	3625	28.2
	1.06	5766	117	7685	126.8

Appendix D-6: Film Splicing and Editing Guidelines

Follow these guidelines to ensure the scanner correctly reads the data holes.

IMPORTANT: When splicing rolls of film, always splice first, then edit.

NOTE: The drawings are not to scale.

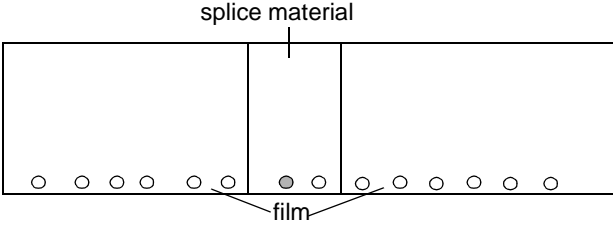
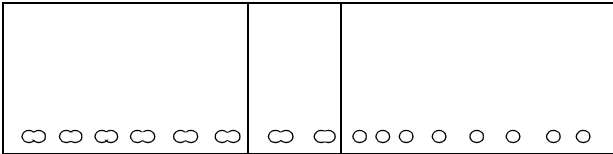
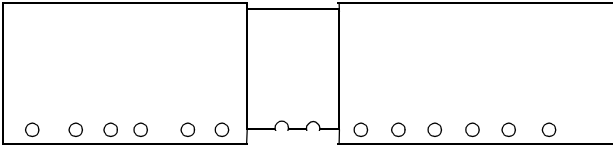
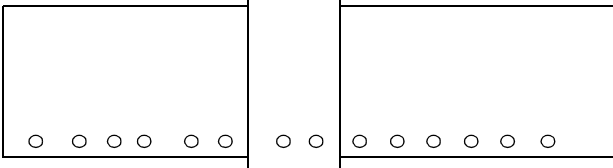
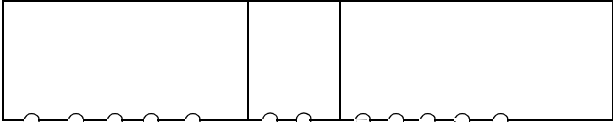
<p>Use care with sticky splice material</p>	<p>Because the splice material is sticky, it is possible for residue to remain on the splice material after editing. Ensure that light can shine through all holes.</p>	
<p>Avoid over-punching</p>	<p>Be careful to avoid accidentally punching a frame twice, which results in too many holes for the scanner to interpret.</p>	
<p>Cut splice material flush with the film</p>	<p>Too much splice material is cut, causing incomplete punches.</p>	
	<p>Not enough splice material is cut. This will interfere with correct film tracking.</p>	
<p>Make sure editing results in holes entirely within the frames</p>	<p>The punches are on the edge of the film. The punches must be completely within the frames.</p>	

Numerics

70MM-CAL film holder **1-6, 2-6, 2-8, 3-1, A-7**

A

AC input module **2-2**
AC voltage and current draw **C-1**
AC voltage setting, changing **2-3 to 2-4**
accessories, ordering **B-1**
adjustment tool for Long Roll Accessory, installing **D-21**
air
 canned or pressurized **4-1, D-7, D-16, D-39**
 ionized **D-1, D-16**
altitude, maximum (operating environment) **C-1**
ambient light (operating environment) **C-1**
autofocusing the scanner **3-7, A-4, A-5**

B

backing up data files **3-2, A-2, A-11, D-4**

C

cables, attaching power and SCSI **2-5**
calibrate/image processing tab (SAM) **A-6 to A-7**
calibrating the scanner **2-8, 3-4, A-7**
 when to do **1-3, 2-9, 4-3, 4-5, 4-7, 4-9**
capture tab (SAM) **A-8 to A-9**
cleaning procedures **4-1 to 4-3, D-39 to D-41**
 balance filters **4-7**
 IR filter **4-9**
 lens **4-2**
 light bar **4-3**
 punch readers on Long Roll Accessory **D-39**
 rollers on Long Roll Accessory **D-40 to D-41**
clearances, for operation and service of scanner **C-1**
configuration, recommended for the host computer **1-5**
connecting the scanner **2-2 to 2-5**
 attaching the cables **2-5**
 changing the AC voltage setting **2-3 to 2-4**
connector on scanner, cleaning **D-7**
core locator height on spindle of Long Roll
 Accessory **D-15**

D

dataplate **1-4**
depth of field **2-13**
dimensions and weight of scanner **C-1**
downloading software and firmware for the
 Long Roll Accessory **D-2**
dust **4-1, D-23**

E

Electrical Hazard symbol **vi**
e-wipes, for cleaning the light bar **4-3**
 ordering **B-2**

F

fast forward or rewind speed
 on Long Roll Accessory **D-1, D-31**
FCC compliance **v**
film cleaner **D-1**
 ordering **B-1**
Film Controls window (SAM), for the Long Roll
 Accessory **D-20**
film cores for the Long Roll Accessory **D-1**
film holder guide **2-6**
 removing from the scanner **D-6**
film holders, cut-gate
 70MM-CAL **1-6, 2-6, 2-8, 3-1, A-7**
 placing in the scanner **2-6, 2-12**
 provided with scanner **1-6**
film reader height on Long Roll Accessory
 visually checking **D-22**
film sizes **1-6**
filters, balance
 cleaning **4-7**
 replacing **4-6 to 4-7**
filters, IR
 cleaning **4-9**
 replacing **4-8 to 4-9**
firmware, upgrading **D-3 to D-4**
flange, orientation of, on Long Roll Accessory **D-16**
focusing **2-13**
 when to do **1-3**
 see also autofocusing
Fuse label **v**

H

host computer, configuration **1-5**
Hot Surface symbol **v**
humidity, relative (operating environment) **C-1**

I

image processing parameters, setting **A-7**
initializing sensors for the Long Roll
 Accessory **D-42 to D-44**
initializing the scanner **A-10**
installing
 Long Roll Accessory on scanner **D-5 to D-13**
 SAM on the host computer **A-2**
IR filter
 cleaning **4-9**
 replacing **4-8 to 4-9**

K

K-number, on scanner **vii, 1-4**
Kodak Professional Digital Print Production Software
 (DP2) **1-3, D-1, D-23**
Kodak Professional HR 500 TWAIN Data Source **1-3**

L

lamp
 replacing **4-4** to **4-5**
 turning on and off **A-10**, **D-19**
lamp timer, resetting to zero **A-10**
lamp-and-filter-access door **2-8**, **4-4**
latch release screw **1-4**
lens, cleaning **4-2**
light bar **D-12**
 cleaning **4-3**
loading and threading film on the Long Roll
 Accessory **D-16** to **D-19**
location of scanner (specifications) **C-1**
Long Roll Accessory **D-1** to **D-46**
 attaching to scanner **D-8** to **D-10**
 calibrating sensor offsets **D-24** to **D-33**
 fast forward or rewind speed **D-1**, **D-31**
 initializing sensors **D-42** to **D-44**
 installing accessory on scanner **D-5** to **D-13**
 installing software **D-2** to **D-4**
 loading and threading film **D-16** to **D-19**
 maintaining **D-38** to **D-41**
 parts shipped with **D-5**
 punch sensors **D-14**
 removing from scanner **D-13**
 setting punch reader height **D-14** to **D-23**
 setting trigger points **D-34** to **D-37**
 splicing and editing guidelines **D-46**
 table of scan area values **D-45**
 threading diagram **D-18**

M

mag/focus tab (SAM) **A-4** to **A-5**
magnification, setting **2-8**, **3-3**, **A-5**
maintaining the scanner **4-1** to **4-9**, **D-38** to **D-41**
 cleaning procedures **4-1** to **4-3**
 Long Roll Accessory maintenance **D-39** to **D-41**
 replacement procedures **4-4** to **4-9**
 balance filters **4-6** to **4-7**
 IR filter **4-8** to **4-9**
 scanner lamp **4-4** to **4-5**
Mechanical Hazard symbol **vi**
miscellaneous tab (SAM) **A-10**

N

negative or mounted slide, inserting in the scanner **2-10**
negative or positive balancing filter, setting **2-8** to **2-9**

O

operating the scanner **2-8** to **2-13**
 focusing **2-13**
 inserting a negative or mounted slide in the scanner **2-10**
 placing the film holder in the scanner **2-12**
 preparing an uncarded negative or a mounted slide **2-11**

 scanning a single frame **2-13**
 selecting negative or positive balancing filter **2-8** to **2-9**
 setting the magnification and calibrating the scanner **2-8**
 setting the scan parameters **2-8**
operations tabs (SAM)
 backup **3-2**, **A-2**, **A-11**
 calibrate/image processing **A-6** to **A-7**
 capture **A-8** to **A-9**
 mag/focus **A-4** to **A-5**
 miscellaneous **A-10**
ordering information **B-1** to **B-2**
 accessories **B-1**
 supplies **B-1**

P

parts shipped with Long Roll Accessory **D-5**
phone numbers
 service agreement information **viii**
 service and support **vii**
power consumption and thermal load of scanner **C-1**
power switch **1-4**, **2-7**
powering up the scanner and the host computer **2-7**
punch readers on the Long Roll Accessory
 cleaning **D-39**
 setting height **D-14** to **D-23**

R

readers, punch. See punch readers
rebooting the scanner **A-10**
regulatory information **v**
removing the Long Roll Accessory from the scanner **D-13**
replacement procedures **4-4** to **4-9**
rollers on the Long Roll Accessory, cleaning **D-40** to **D-41**

S

SAM. see Service and Assembly Module
scan area values
 for cut-gate film holders **3-6**
 for the Long Roll Accessory **D-45**
scan area, setting, in SAM **3-5** to **3-6**, **A-9**
scan parameters, setting **2-8**
scan, checking **3-8**
scanner attributes **A-10**
scanner specifications **C-1**
 AC voltage and current draw **C-1**
 clearances, for operation and service of scanner **C-1**
 dimensions and weight **C-1**
 location **C-1**
 power consumption and thermal load **C-1**
scanning
 a single frame **2-13**
 an image using SAM **3-8**, **A-9**
SCSI host adapter **1-5**
SCSI interface between host computer and scanner **1-5**

sensor offsets on the Long Roll Accessory,
 calibrating **D-24 to D-33**
 sensors, punch (data hole) on the Long Roll
 Accessory **D-14**
 serial number on the scanner **1-4**
 Service and Assembly Module (SAM) **A-1 to A-11**
 installing on the host computer **A-2**
 operations controls **A-3 to A-11**
 backing up data files **3-2, A-2, A-11**
 calibrating the scanner **A-7**
 performing an autofocus **A-5**
 scanning the image data **A-9**
 setting image process parameters **A-7**
 setting the magnification **A-5**
 setting the scan area **A-9**
 starting **3-1 to 3-2**
 service, obtaining **vii**
 shutting down the scanner **2-13**
 site specifications **C-1**
 AC power requirements, frequency, and phase **C-1**
 altitude, maximum (operating environment) **C-1**
 ambient light (operating environment) **C-1**
 humidity, relative (operating environment) **C-1**
 temperature, room (operating environment) **C-1**
 slide, mounted, preparing **2-11**
 software
 installing for the Long Roll Accessory **D-2 to D-4**
 installing SAM **2-1, A-2**
 requirements for host computer **1-5**
 specifications
 scanner **C-1**
 site **C-1**
 splicing guidelines for the Long Roll Accessory **D-46**
 starting up the scanner system **2-6 to 2-8**
 placing the empty film holder in the scanner **2-6**
 powering up the scanner and the host computer **2-7**
 static elimination kit **D-1**
 ordering **B-1**
 supplies, ordering **B-2**
 symbols, cautionary, on equipment **v to vi**

T

tables of scan area values
 for cut-gate film holders **3-6**
 for Long Roll Accessory **D-45**
 temperature, room (operating environment) **C-1**
 threading diagram for Long Roll Accessory **D-18**
 threading film on the Long Roll Accessory **D-16 to D-19**
 time, scanner, getting **A-10**
 trigger points on Long Roll Accessory, setting
 D-34 to D-37

U

uncarded negative, preparing **2-11**
 unpacking instructions **iii**
 usage information, getting **A-10**

V

validating operation of the scanner **3-1 to 3-8**
 autofocusing **3-7**
 calibrating the scanner **3-4**
 checking the scan **3-8**
 making a test scan **3-5 to 3-6**
 scanning the image **3-8**
 setting the magnification **3-3**
 starting the Service and Assembly Module **3-1 to 3-2**
 version information, getting **A-10**
 voltage selector switch **2-3**

W

warranty information **vii to viii**
 limitations of warranty **viii**
 repair coverage **vii**
 warranty period **vii**

EASTMAN KODAK COMPANY
Rochester, New York 14653
U.S.A.

Kodak and Kodak Professional are
trademarks of
Eastman Kodak Company.

